



INDUSTRIAL TANK MIXERS

GMX SERIES

At Dynamix, we provide experience-driven mixing solutions



Missouri Filter & Process Equipment Co
 MOFILCO - Quality, Value, Service
 12025 Manchester Road, Suite 30G
 St Louis MO 63131
 314-821-4321 www.mofilco.com
 mofilco@mofilco.com

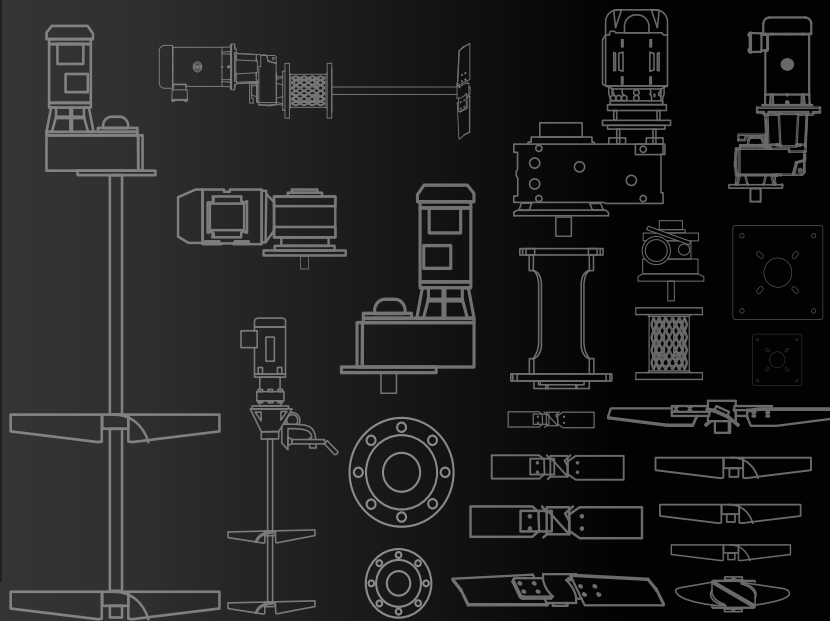

INDUSTRIAL TANK MIXERS

GMX Series

Power and Flexibility for Your Process

This intermediate mixer for 2,500 to 30,000 + gallon tanks has an uncompromising design built to suit your unique application. Contact us now if you have a short lead time or a difficult application.

CONFIGURATION OPTIONS

MOTOR	HP Range: 0.5 to 5.0	» A full range of motors is available for this series.
GEAR REDUCTION	Helical and Helical Bevel	» AGMA Rating, minimum service factor of 1.5
MOUNTING	Plate, Flange, and Angle Mount	» Offers flexibility in adapting to your tank and optimizing mixing.
IMPELLER	Dynamix P3B High Efficiency Pitch	» Standard: P3B Hybrid Blade. Other options are available



WHY DYNAMIX?

- ✓ PROVEN EXPERIENCE Over 45 years of process engineering experience.
- ✓ WIDE RANGE OF MIXERS From 0.25 hp to 500 hp Industrial Agitators.
- ✓ CUSTOMIZED MIXING SOLUTIONS A team of chemical and mechanical engineers and other experts are ready to help configure your perfect

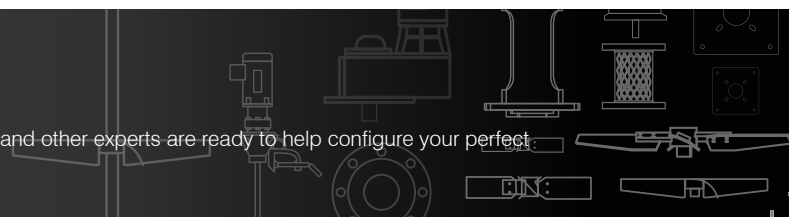

GMX Series Features

Configuration Options

MOTORS NEMA C-Face motors with a power range from 0.5 to 5.0 HP are standard.

GEARS The GMX features a minimum service factor of 1.5 and a parallel shaft with high quality helical gears.

Up to AGMA Class 10 gear quality and gear hardness of 58 Rockwell C minimum.

*Also available with low profile right angle gear boxes.

BEARINGS Standard deep groove ball bearings are rated for over 50,000 hours L-10 bearing life.

HOUSING A strong and rigid one-piece housing design is crafted from SAE 30 gray iron and features exceptional housing torsional stiffness and a thick housing wall section.

OIL SEALS Quadrilip output oil seals protect the gearbox from the harshest environments and offer redundant protection for your application from contamination.

SHAFT MOUNTING Shaft mounting options available include hollow quill or solid shaft with flange coupling for ease of assembly in the field. Optional flange is available to allow quick disassembly of gearbox from mixer shaft for service.

CONSTRUCTION MATERIALS Carbon Steel and Stainless Steel are standard construction materials. Other materials and coating options are also available to address issues such as abrasion / corrosion resistance.

Agitator Mounting Options

FLEXIBILITY The GMX Series features flexible mounting options fabricated from thick steel. Flange, Plate, or Angled Plate Mounts ensure compatibility with a wide range of tanks and supports.

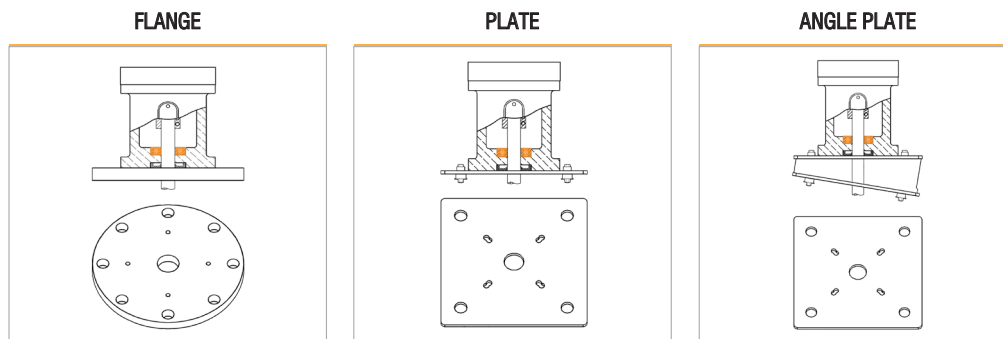

Customizable Impellers

P3B HIGH-EFFICIENCY PITCH The P3B High-Efficiency Pitch impeller bridges the gap between the benefits of our P4 Pitch impeller and the low shear of our Dynaflo™ impeller. The design benefits of this impeller include easy installation and an economical price.

*Other impellers also available. (see pictures)

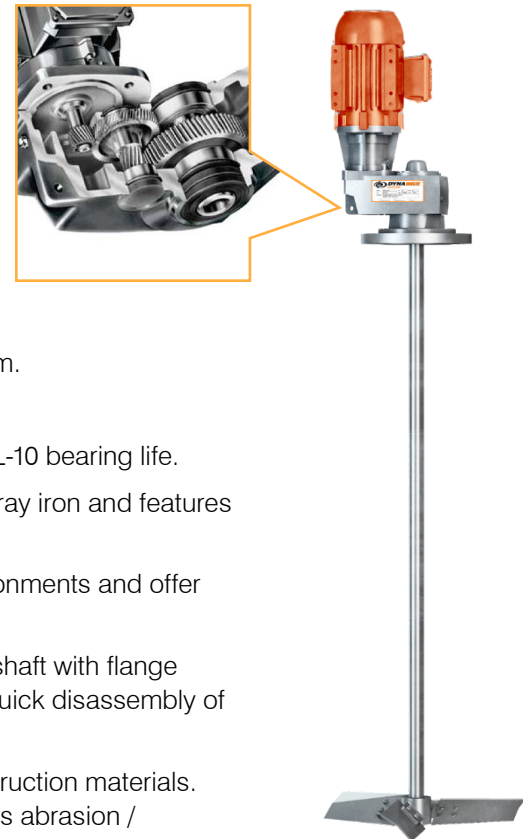

IMPELLERS: 1-Dynaflo™ 2-Pitch 3-Radial

HOW TO GET STARTED

To work with our application engineers, call us at 1-866-563-2448 to request a quote and find out how we can optimize the quality of your application results.

TEL: 1-866-563-2448

EMAIL: info@dynamixinc.com

DYNAMIX AGITATORS

www.dynamixinc.com

