



A Division of RGF Environmental Group, Inc.

1101 W. 13th Street
Riviera Beach, Florida 33404
(561) 848-1826
www.rgf.com/afl-industries

VTC (OIL WATER SEPARATOR) - SPECIFICATION SHEET

VTC Series - Vertical Tube Coalescing Oil Water Separator
Fiberglass, Stainless Steel and Carbon Steel
Flow Rates 0-2400 GPM in a Single Tank
Separate hydrocarbons from wastewater and storm water



ENGINEERING A BETTER ENVIRONMENT



VTC-300 Fiberglass
Above Ground



Missouri Filter & Process Equipment Co
MOFILCO-Quality, Value, Service
12025 Manchester Road, Suite 30G
St Louis MO 63131

314-821-4321 www.mofilco.com
mofilco@mofilco.com



VTC-20 Stainless Steel
Above Ground

The VTC removes 'free' hydrocarbons and settleable solids from industrial waste water and coolant. In operation, the VTC accepts industrial liquid waste in the inlet chamber where settleable solids fall to the bottom as sludge for periodic removal. The waste stream then enters the coalescing separation chamber where AFL's Delta-Tubes inspire laminar flow characteristics to the liquid as it passes through the separator. The result is a liquid more responsive to gravity separation. The Delta-Tubes primarily provide a coalescing medium for oil globules. Oleophilic in nature, the Delta-Tubes attract small oil globules which coalesce to larger globules, increasing in size and buoyancy, then break away to rise to the surface. Floating oil is collected by a Rotary Pipe Skimmer for collection and disposal in accordance with local regulations.

FEATURES

Reduces free oil content down to <10 ppm
Removes oil droplets >20 micron
Fiberglass, stainless and carbon steel

Pre-engineered, ready to install
No power, gravity flow or fully automated
Conforms to API design standards

VTC (OIL WATER SEPARATOR) - SPECIFICATION SHEET



ENGINEERING A BETTER ENVIRONMENT

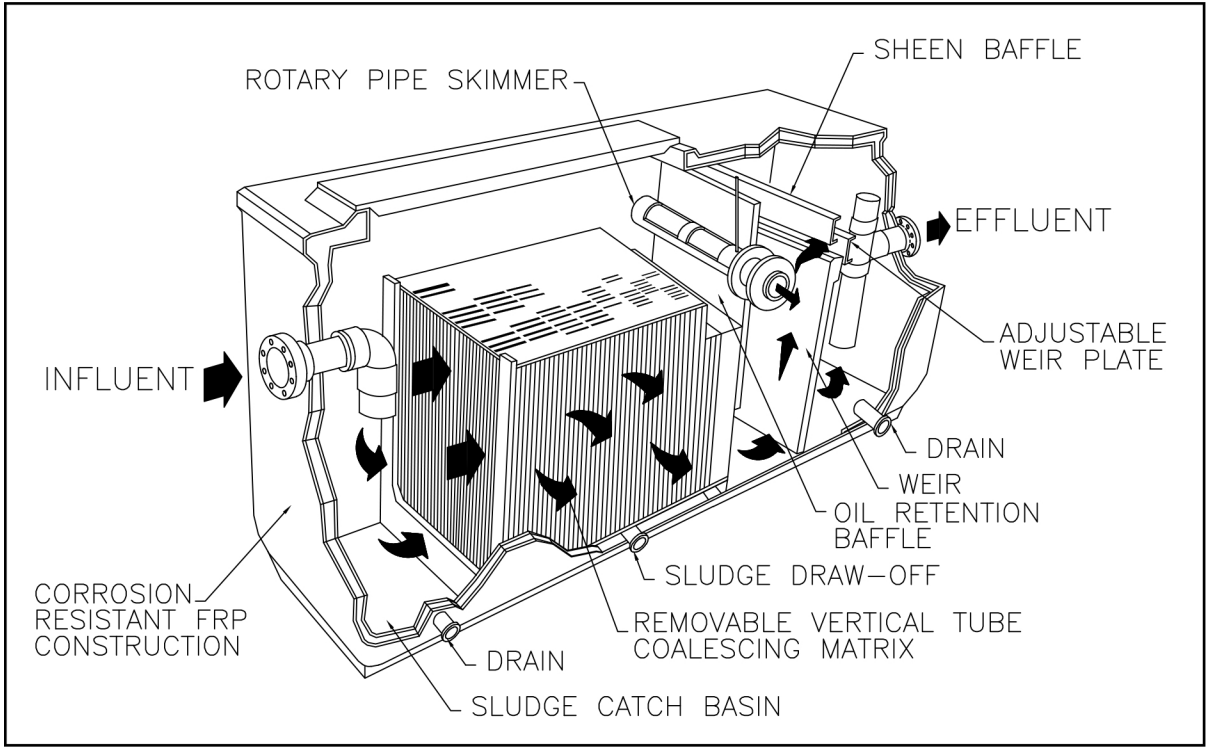

VTC Options

Oil Stop Valve Installed
Ladders and Hand Rails
Freeze Protection
Controls and Automation

Internal Oil Storage
External Oil Storage
Custom Oil Skimmers
Influent and Effluent Pumps

Sludge and Waste Oil Pumps
Fiberglass Construction
Stainless Steel Construction
Carbon Steel Construction

VTC Series - Technical Specifications

Model	Flow Rate	Volume	Dimensions	Installation
VTC-5-SS	5 GPM	34 Gal.	2.75' x 1.5' x 1.4' H	Above
VTC-10-SS	10 GPM	91 Gal.	4' x 2' x 2' H	Above
VTC-20-SS	20 GPM	290 Gal.	6.4' x 2.7' x 4.4' H	Above
VTC-50-SS	50 GPM	797 Gal.	6' x 5.5' x 4.4' H	Above/Flush/Below
VTC-100	100 GPM	942 Gal.	10.5' x 2.5' x 6.4' H	Above/Flush/Below
VTC-200	200 GPM	1,420 Gal.	10.5' x 4.3' x 6.4' H	Above/Flush/Below
VTC-300	300 GPM	2,130 Gal.	10.5' x 6.3' x 6.4' H	Above/Flush/Below
VTC-400	400 GPM	2,840 Gal.	10.5' x 8.4' x 6.4' H	Above/Flush/Below
VTC-500	500 GPM	3,560 Gal.	10.5' x 10' x 6.4' H	Above/Flush/Below
VTC-600 to 2400	Flow rates from 600 to 2,400 gpm in a single unit			Above/Flush/Below

AFL's VTC series oil water separators conform to API Standard 421 for the Design and Operation of Oil Water Separators.