

## QUADRO PROCESS PRODUCTIVITY SOLUTIONS

### IN-LINE INTEGRATION

The Quadro® FlexSift easily integrates into your processing suite with minimal effort. Typical installation examples:

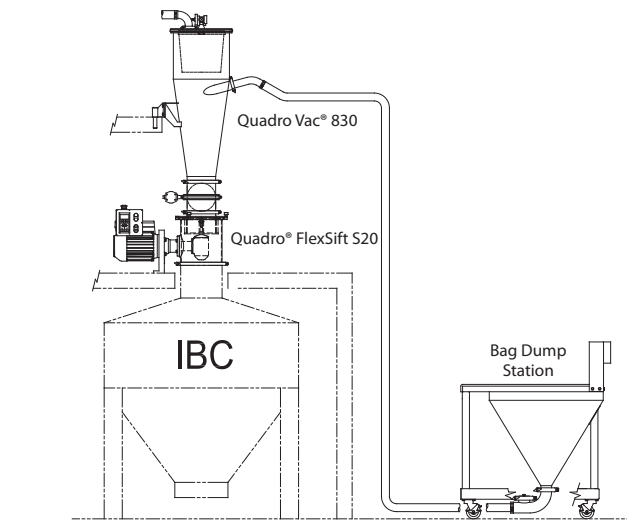

Sieve System

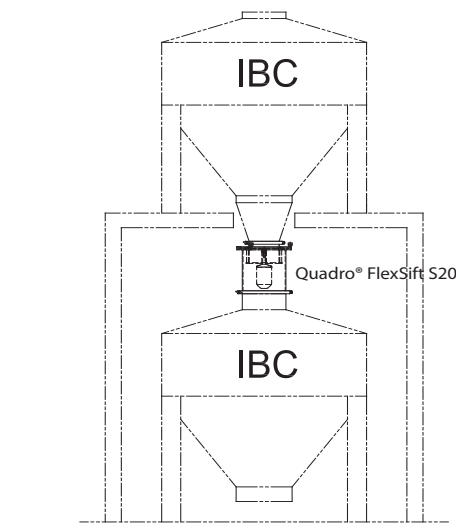

Direct Couple to IBC

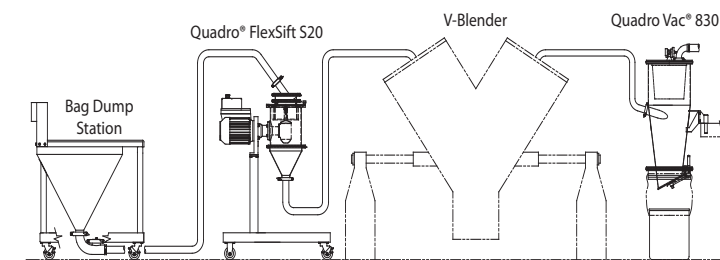

Sieve & Blend System

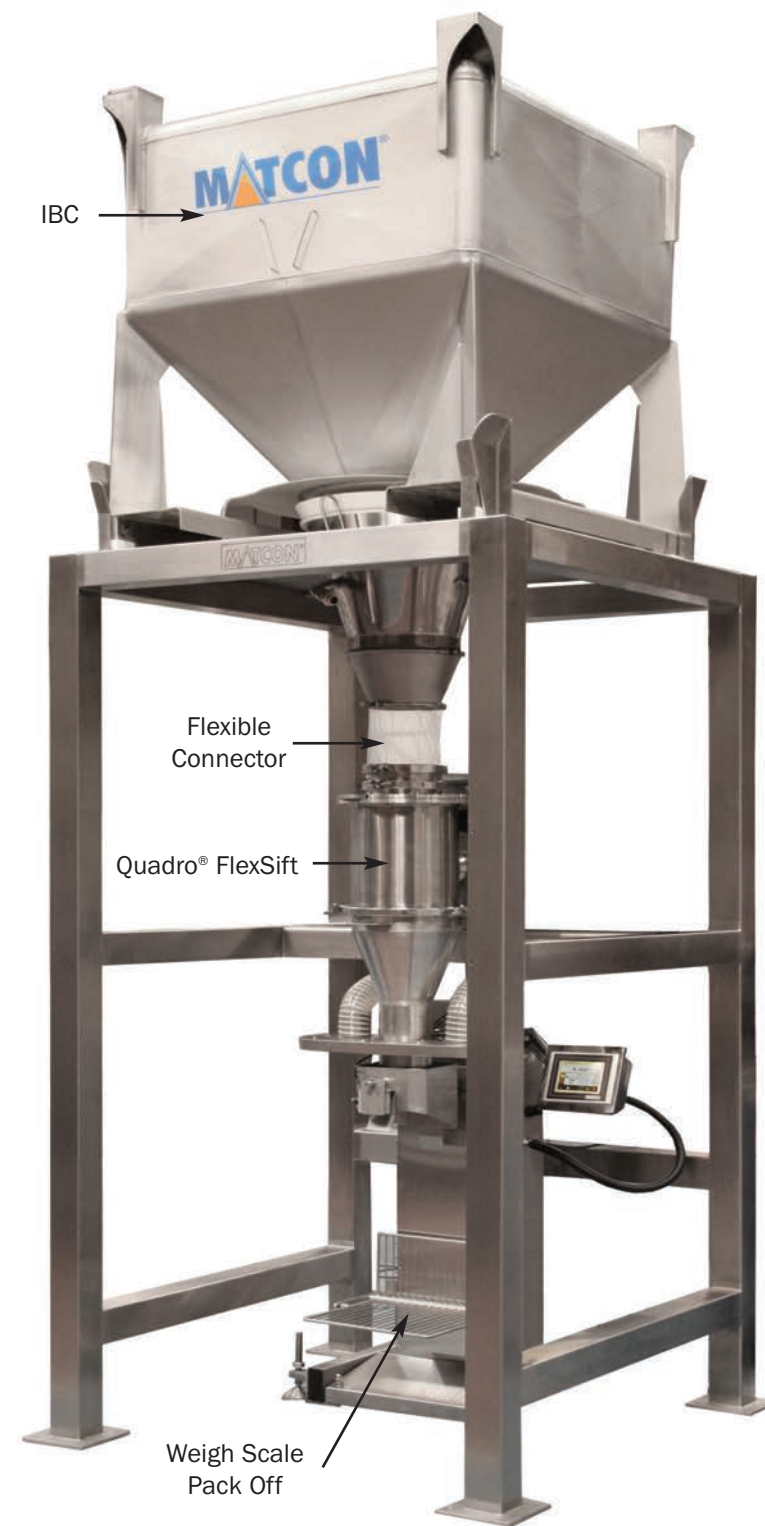

For over 30 years, Quadro has made an unparalleled commitment to delivering the highest production efficiencies, product quality and consistency to market leaders in the Pharmaceutical, Food, Fine Chemical, Personal Care and Cosmetics industries worldwide.



With the engineering experience gained from developing reliable application-specific solutions for major processors in more than 80 countries, our knowledge of size reduction and dispersion is unmatched. In fact, meeting the evolving needs of our customers drives the development of some of the industry's most advanced processing technologies and systems – such as the Quadro® Comil®, Quadro® FlexSift, Quadro® Fine Grind, Quadro Ytron® in-line mixers, dispersers and emulsifiers, Quadro® ShearFX, Quadro® HV-Emulsifier and Quadro Vac® vacuum transfer systems.

Since 1976, Quadro has led the industry in research & development. Through the Quadro R&D Test Center we work



directly with our customers to run real-world tests of their processes on the latest Quadro equipment. The result has been technical breakthroughs that have changed the way many of our customers manufacture, and led to new global processing industry standards.

As the world's leading supplier of size reduction technology – with a vast global network of agents, distributors, OEMs and partners – Quadro provides a level of service and technical support that is unequalled in the industry. Our passion for technology is exceeded only by our dedication to meeting the needs of our customers.



SIZE REDUCTION • FLUID MIXING • PNEUMATIC TRANSFER



LOCAL REPRESENTATIVE



613 Colby Drive  
Waterloo, ON, CA N2V 1A1



832 Industrial Drive  
Elmhurst, IL 60126

Telephone: 519-884-9660  
Fax: 519-884-0253

quadrosales@idexcorp.com • www.quadromaterialhandling.com

# Quadro® FlexSift

HIGH-CAPACITY SECURITY SCREENING AND DE-AGGLOMERATION





# THE CUTTING EDGE IN HIGH-CAPACITY SECURITY SCREENING AND DE-AGGLOMERATION TECHNOLOGY

Quadro brings sifting technology to a whole new level. The Quadro® FlexSift is the cutting edge in high-capacity **security screening** and **de-agglomeration** technology. The Quadro® FlexSift effectively captures and retains impurities and other foreign materials easily and efficiently in a simple in-line configuration.

## Increased Safety

By pre-screening material before it enters downstream equipment, the Quadro® FlexSift reduces risk of contamination of final processed product, prevents damage to equipment and injury to personnel.

## De-agglomeration Simplified

The Quadro® FlexSift is also a very efficient means of de-agglomerating powders. Agglomeration is typically caused by particles or powders adhering to one another as a result of exposure to environmental conditions such as static, heat, cold or moisture during shipping or storage. The rotating action of the FlexSift combined with the custom designed spoiler arm gently de-agglomerates without reducing the size of the particles. The spoiler arm also aids in the sifting of very fine particles, typically in the 50 mesh (300 micron) and below range, which traditional sifting technologies have difficulty in passing through their screens. Sifting efficiency is effectively improved by approximately 80%.

## Proven Performance

Based on Quadro's proven technology, the unique, in-line design of the Quadro® FlexSift reduces the amount of air-borne fine particles, minimizing product waste, and limiting operator exposure.

## Compact Design

The Quadro® FlexSift is compact and the low profile design fits below most bulk bag unloader and mixer discharges and easily integrates into most systems.

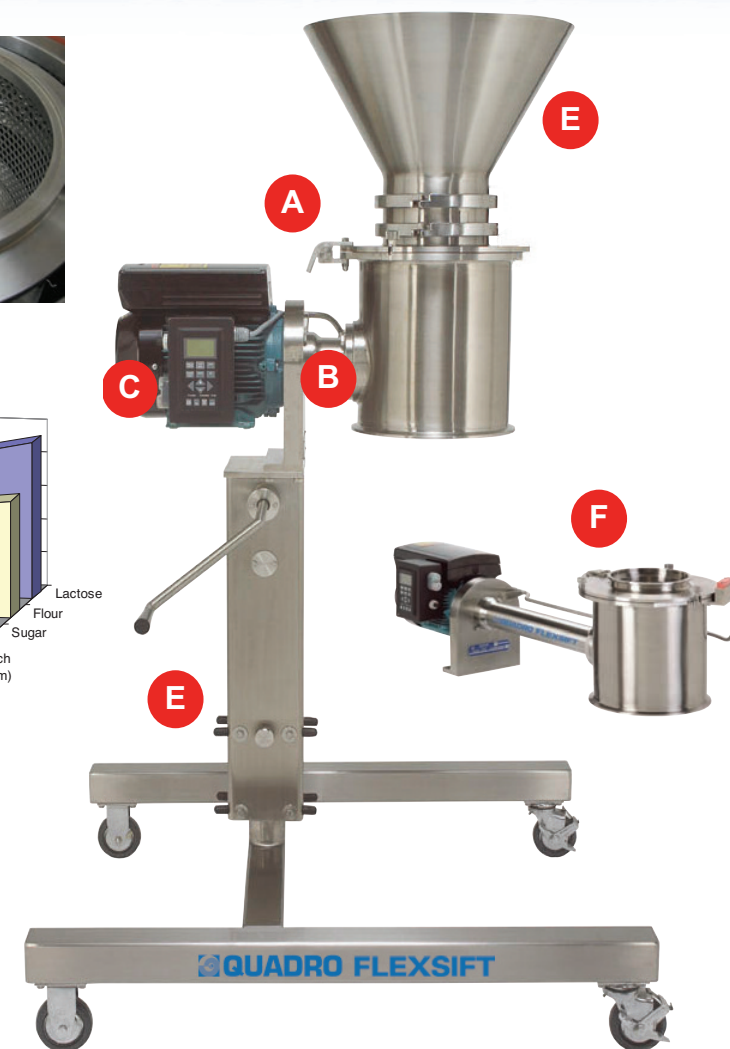
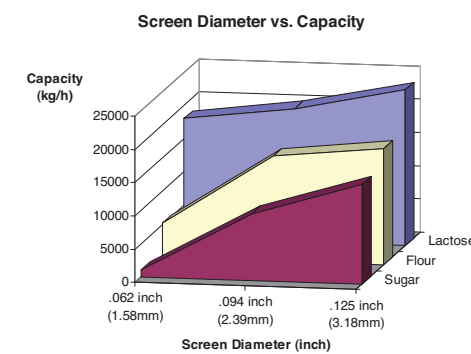
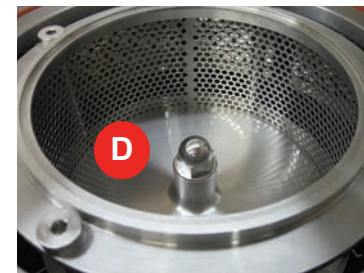

## FEATURES

- A Compact, in-line design**
  - low profile design fits below most bulk bag unloader and mixer discharges
- B Positive, 360° discharge**
  - effectively segregates and retains impurities and other foreign materials cutting sifting times up to 80%
- C User-friendly design**
  - easy-to-use controls
  - can be control or bulk-fed
- D Easy-to-clean/maintain**
  - minimal number of parts - single bolt locking mechanism secures the screen assembly onto the gearbox for fast changeover and maintenance
  - quick screen changes with no special tools required
- E Wide variety of options available**
  - variable height lift stand
  - hand-feed hopper
  - wide range of screen sizes available to meet your specifications
- F Customizable to fit any process stream**
  - range of spindle lengths available
  - suitable for vacuum discharge and dust-free pneumatic conveying

## PRINCIPLE OF OPERATION

As compared to traditional vibratory sifters, the Quadro® FlexSift does not employ vibration to sift the material entering the action zone.

- A The infeed product falls into the sifting chamber.**
- B Centrifugal acceleration ensures a continuous flow of material through the screen openings while simultaneously retaining impurities.**
- C Finished product is discharged 360° around the screen to enhance product flow.**
- D Impurities and other foreign materials collected in the screening chamber can be easily removed or suctioned off by an optional vacuum adaptor.**

## S20 TYPICAL CAPACITIES\*

Product	Screen Hole Diameter inches (mm)	Capacity (kg/hr)	Capacity (lbs/hr)
Salt	0.062" (1.6)	8500	18,700
	0.094" (2.4)	45,000	99,000
	0.125" (3.2)	50,000	110,000
Sugar	0.045" (1.1)	500	1100
	0.062" (1.6)	1000	2200
	0.094" (2.4)	10,000	22,000
Flour	0.125" (3.2)	15,000	33,000
	0.045" (1.1)	4200	9200
	0.062" (1.6)	5200	11,400
Lactose	0.094" (2.4)	15,800	34,700
	0.125" (3.2)	17,500	38,500
	0.018" (0.5)	1000	2200
Starch	0.045" (1.1)	17,500	38,500
	0.062" (1.6)	18,000	39,600
	0.094" (2.4)	20,000	44,000
Coffee Flavor	0.125" (3.2)	23,400	51,400
	0.062" (1.6)	22,500	49,500
	0.062" (1.6)	7500	16,500
Cocoa Powder	0.062" (1.6)	6300	13,800
	0.039" (1.0)	5000	11,000
	0.018" (0.5)	3900	8500
Food Flavoring	0.018" (0.5)	3900	8500
	0.079" (2.0)	16,800	36,900

\*Typical capacities of the S10 are 1/3 that of the S20.

## TECHNICAL SPECIFICATIONS

Quadro® FlexSift	Model S5	Model S10	Model S20
<b>Power - HP (kW)</b>	1 (0.75)	2 (1.5)	5 (4.0)
<b>RPM</b>	700 - 1400	700 - 1400	700 - 1400
<b>Sound Level</b>	<80dBA	<80dBA	<80dBA
<b>Approximate Dimensions</b>	<b>in</b>	L x W x H 26 x 15.5 x 20.5	L x W x H 23.5 x 13 x 14
	<b>mm</b>	L x W x H 655 x 394 x 517	L x W x H 599 x 326 x 351
<b>Approximate Screen Diameter</b>	<b>in</b>	3.25	5.25
	<b>mm</b>	82.6	133.4

\* Dimensions include base.

## QUADRO® FLEXSIFT LAB-SCALE MODEL S5

- The innovative FlexSift technology is available in bench-top/lab-scale size with the Model S5
- Typical capacities of approximately 500 kg/hr (1100 lbs/hr)\*
- Also available is the S5/U5 integrated configuration which features removable/interchangeable FlexSift S5 and Comil U5 heads



\*Dextrose, 1400 RPM, 045R screen, using optional wiper arm.

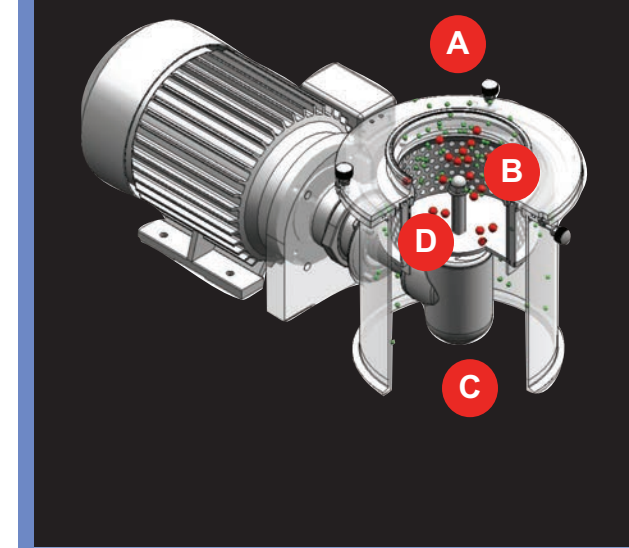

## FLEXSIFT DE-AGGLOMERATION CAPABILITIES

Quadro® FlexSift with optional spoiler arm



Feed material to FlexSift



Post discharge from FlexSift

