

# Vincent



## Fiber Filter





SLUDGE DISCHARGE INTO 5-GALLON PAIL

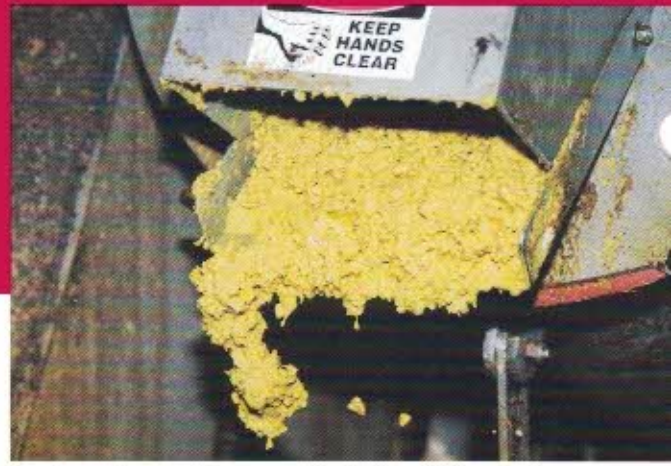

THICK SLUDGE DISCHARGE



FF-12 FILTERING WASTEWATER AFTER DRUM SCREENS



FILTER SLEEVE ASSEMBLIES



LOW SET ELEVATION FOR HEAVY CAKE DISCHARGE

**Vincent**  
CORPORATION





**MODEL FF-6 FIBER FILTER**

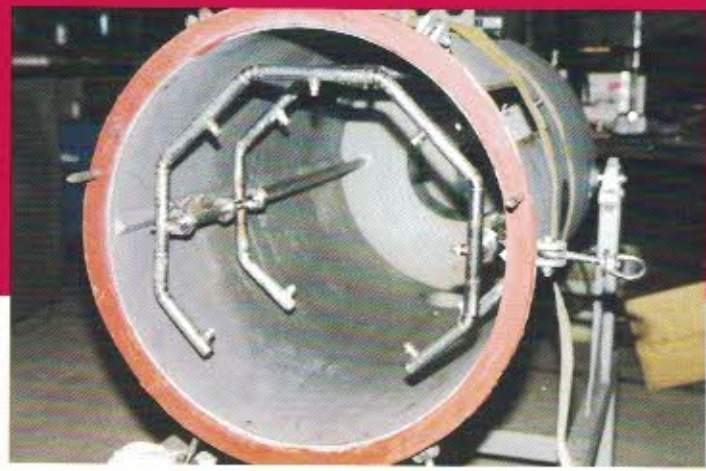

**DUAL SPRAY RINGS FOR BACKFLUSH**



**MANY ROTOR DESIGNS ARE AVAILABLE**



**JUICE FINISHING**



**AIR CYLINDER ACTUATOR FOR BACKFLUSH SPRAY**

# FIBER FILTER

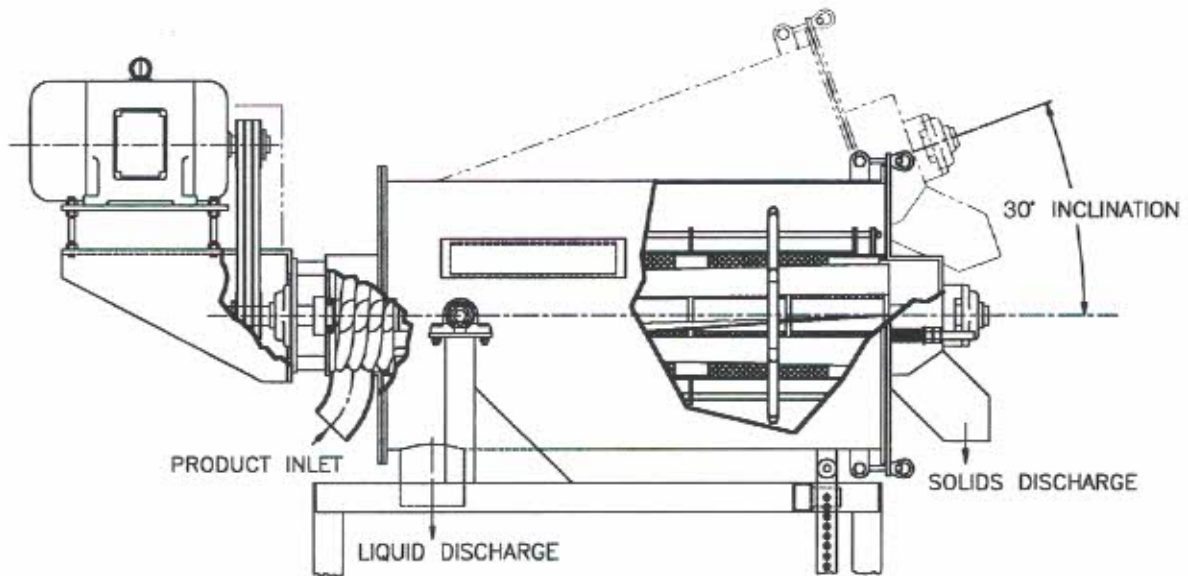

Featuring fine filtration of high gpm throughputs, the Fiber Filter is a unique machine. It operates continuously with a fabric filter that is vibrated clean by the process flow, requiring only occasional back-flush cycles.

Liquid flows with fiber contents ranging from 0.3% to 4.0% are thickened to a range of 6% to 14% solids with the Fiber Filter. The filtrate liquid is remarkably clear. The Fiber Filter can replace equipment ranging from pre-thickening screens to centrifuges. Fiber Filters can be used both to thicken flow ahead of a screw press and to remove fiber from press liquor.

Mechanically the Fiber Filter has a rotating

paddle impeller that whirls and pulses the incoming fluid against the inside of a cylindrical filter screen. The filter sleeve, held taught in a frame, is made of woven polymer fabric. The fabric is available in meshes ranging from 20 microns (.001") to 200 microns (.008"). Fabric tension is adjusted from outside the machine, improving sanitation and facilitating operation.\* Back-flushing may be required to maintain peak throughput capacity. A wash nozzle manifold for use with water or filtrate is included with all machines, along with a booster pump and control panel.

\*US Patent 6,117,321

Model	HP	Capacity* GPM	Weight LBS	Dimensions (feet) L x W x H
FF 6	3	25 - 150	700	6 x 2 x 4
FF 12	10	100 - 500	1600	8 x 3 x 5
FF 30	30	300 - 1500	2400	10 x 4 x 6

\*SUBJECT TO ON-SITE TESTING.

# Vincent

## CORPORATION

Tampa, Florida ● Tel. (813) 248-2650 ● Fax (813) 247-7557 ● [www.vincentcorp.com](http://www.vincentcorp.com)

5M4/01