

500 Series

PRODUCT BROCHURE



Where Innovation Flows



Reliability. Accuracy. Peace of mind. These are things that Neptune™ provides through our innovative water treatment solutions. Since 1961, Neptune has manufactured the benchmark in hydraulic and mechanical diaphragm metering pumps, chemical feed systems, mixers and accessories. This commitment to quality and precision allows operators to maintain peace of mind and continued performance across a variety of industries, including agriculture, energy, mining, chemical processing, and water/wastewater treatment.



HYDRAULIC METERING SOLUTIONS



Neptune™ 500 Series Hydraulic Metering Pumps

The Neptune 500 Series hydraulic metering pumps are perfect for metering applications. Each pump features a variable Oil By-Pass™ stroke adjustment mechanism which will allow better valve performance than variable linkage designs. The valve checks have extra time to seat even in heavy liquids since they are idle during the by-pass portion of the suction and discharge strokes. 500 Series pumps are available in simplex and duplex configurations with capacities up to 94 gallons per hour.

FEATURES & BENEFITS:

- Ten turn micrometer dial calibrated in 1% increments
- Bright color contrasted dial protected from corrosion by clear PVC covering
- Stroke mechanism moves only when adjustment is made, eliminating wear
- Piston is powered through complete stroke length at all capacity adjustments eliminating stress, wear and shock of lost motion designs
- Standard integrally mounted motors are totally enclosed, fan-cooled, with built-in automatic thermal overload
- Internal relief valve automatically protects the piping and system from overpressure
- EZE-Clean™ valve system allows valve removal for cleaning without disturbing the piping to the pump (Exceptions: 500-E series and 560 series in PVC and PVDF construction)

Nomenclature HYDRAULIC SERIES PUMP DATA SHEET

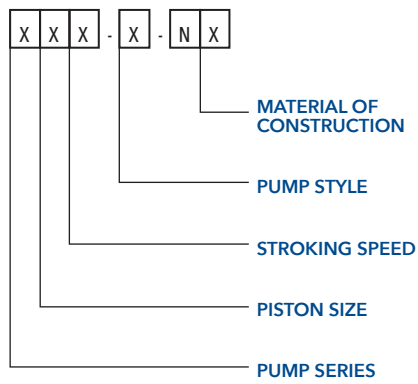

PISTON SIZE

0 = 1/2"	(12.7 mm)
1 = 1/2"	(12.7 mm)
2 = 11/16"	(17.5 mm)
3 = 1-1/16"	(27 mm)
4 = 1-3/16"	(30 mm)
6 = 5/16"	(8 mm)

PUMP STYLE

- A** = Simplex (Non-removable, oil head cannot be converted to Duplex)
- D** = Duplex
- E** = Economy Head on "A" Gear Box
- S** = Simplex (Removable, or head can be converted to Duplex)

STROKING SPEED (Based on 1725 RPM Motor)

(60Hz)	(50Hz)
0 = 37 SPM	0 = 30 SPM
2 = 72 SPM	2 = 60 SPM
5 = 117 SPM	5 = 98 SPM
7 = 144 SPM	7 = 120 SPM
8 = 176 SPM	8 = 144 SPM

MATERIAL OF CONSTRUCTION

- 3** = 316SS Trim, FKM O-Rings, PTFE Diaphragm
- 4** = C-20, FKM O-Rings, PTFE Diaphragm
- 5** = PVC*, Glass** Ball Check, FKM O-Rings, PTFE Diaphragm
- 8** = PVDF, PTFE Diaphragm

* PVC head pumps satisfactory for temperatures to 125°F (52°C).
 ** Special materials available for services not compatible with glass.

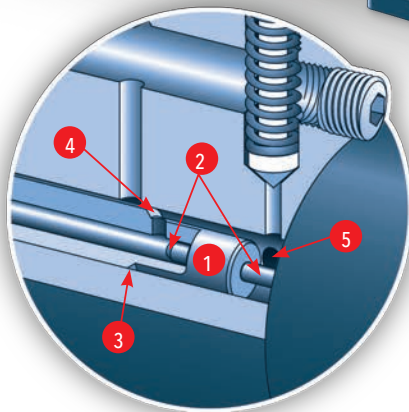
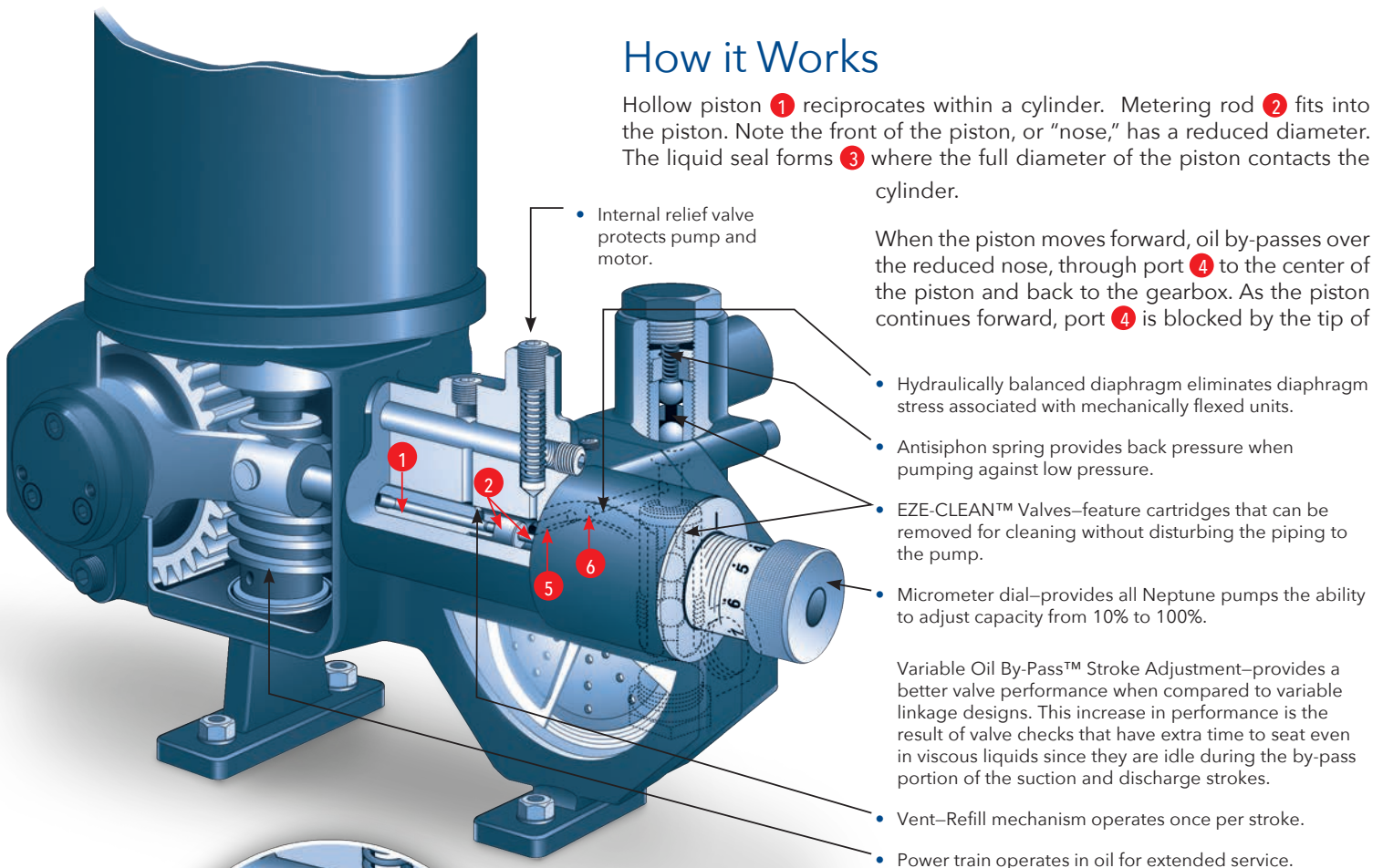

Turning the micrometer dial moves the metering rod and changes the pump capacity. When the metering rod is moved in, the tip of the metering rod closes port **4** sooner in the stroke allowing for less by-pass and more pumping action. Likewise, when the metering rod is moved out, the tip of the metering rod closes port **4** later in the stroke allowing more by-pass and less pumping.

The motion of the piston pushes and pulls the hydraulic fluid through port **5**, into and out of the diaphragm chamber. The action of the fluid pushes and pulls the diaphragm which, in turn, pushes and pulls chemical through port **6**. The action of the check valves controls the direction of the liquid.

HYDRAULIC SOLUTIONS

500-A Series

500-A Series Hydraulic Metering Pump is a Neptune simplex design. This design configuration includes a single micrometer dial with one liquid head. 500-A Series pumps cannot be converted to the duplex design.

- Simplex capacities from 1 gph (3.7 L/h) to 18 gph (68 L/h)
- Pressures up to 1,100 psi (77 bar)



500-A Series DIMENSIONS

EXCEPT PVDF MODELS (CODE N8)*

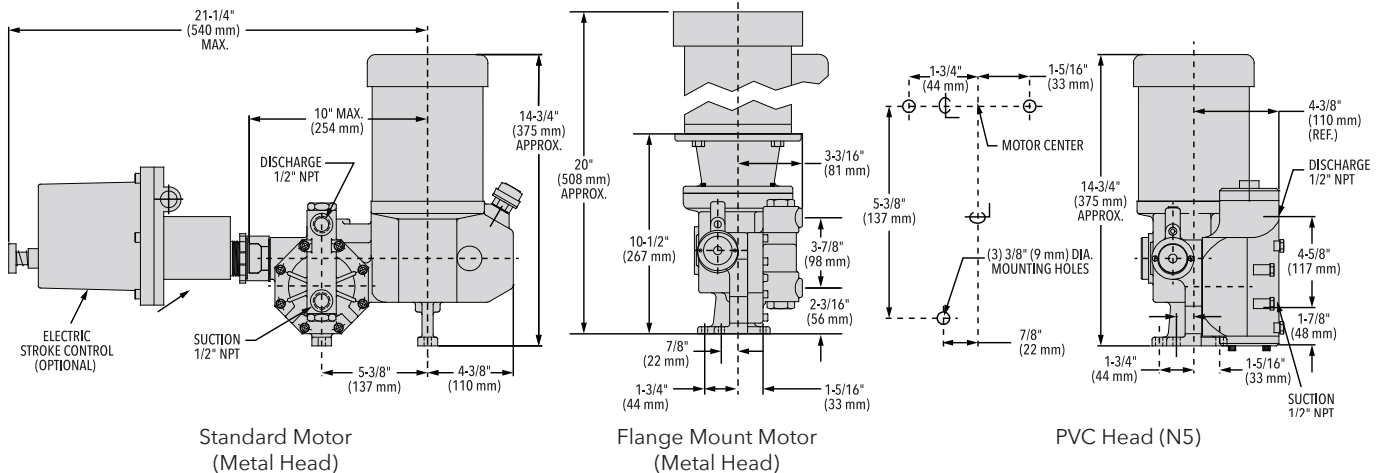

DIMENSIONS ARE APPROXIMATE. SPECIFICATIONS SUBJECT TO CHANGE WITHOUT NOTICE.
*SEE BULLETIN DP-500E FOR PVDF (N8).



500-A Series SELECTION CHART

Standard Motor: 1/3hp-1ph-115VAC-60c-TEFC[†]
SIMPLEX ONLY

MODEL	PISTON DIAMETER INCHES (MM)	STROKES PER MINUTE AT 60 HZ (50 HZ)	MATERIALS OF CONSTRUCTION	CAPACITY AT 100 PSI (7 BAR) 60 HZ (50 HZ)		MAX PRESSURE		SHIPPING WEIGHT LB. (KG)**
				GPH	L/H	PSI	BAR	
500-A-N3 500-A-N4 500-A-N5	1/2 (13)	37 (31)	316SS	0.8 (0.7)	3 (2.5)	1,000	70	60 (27)
C-20 PVC*			1,000 150			70 11		
510-E-N8			PVDF**	0.8 (0.7)	3 (2.5)	150	11	
515-A-N3 515-A-N4 515-A-N5 515-E-N8	1/2 (13)	117 (97)	316SS	3 (2.5)	11.3 (9.4)	1,100	77	60 (27)
C-20 PVC* PVDF**			1,100 400 150			77 28 11		
520-A-N3 520-A-N4 520-A-N5 520-E-N8	11/16 (18)	37 (31)	316SS	2 (1.7)	7.5 (6.3)	700	49	60 (27)
C-20 PVC* PVDF**			700 400 150			49 28 11		
522-A-N3 522-A-N4 522-A-N5 522-E-N8	11/16 (18)	72 (60)	316SS	4 (3.3)	15.1 (12.6)	700	49	60 (27)
C-20 PVC* PVDF**			700 400 150			49 28 11		
525-A-N3 525-A-N4 525-A-N5 525-E-N8	11/16 (18)	117 (97)	316SS	7 (5.8)	26.5 (22)	900	63	60 (27)
C-20 PVC* PVDF**			900 400 150			63 28 11		
530-A-N3 530-A-N4 530-A-N5 530-E-N8	1-1/16 (27)	37 (31)	316SS	5.5 (4.6)	20.8 (17.3)	350	25	60 (27)
C-20 PVC* PVDF**			350 300 150			25 21 21		
532-A-N3 532-A-N4 532-A-N5 532-E-N8	1-1/16 (27)	72 (60)	316SS	11 (9.2)	41.6 (34.7)	350	25	60 (27)
C-20 PVC* PVDF**			350 300 150			25 21 21		
535-A-N3 535-A-N4 535-A-N5 535-E-N8	1-1/16 (27)	117 (97)	316SS	18 (15)	68.1 (56.8)	350	25	60 (72)
C-20 PVC* PVDF**			350 300 150			25 21 21		
547-S-N8§	1-3/16 (30)	144 (120)	PVDF**	29 (24)	110 (91)	150	11	70 (32)

† See page 9 for motor options available. IEC metric motor adapter available.

§ Model 547 furnished with integral 1/2HP-1ph-115VAC-TEFC motor as standard.

* For sodium hypochlorite service, refer to Bulletin DP-500E.

** PVDF material options are only available in the 500-E series models. For more information please see bulletin DP-500E.

*** Standard motor only. For flange mounted motor, add 20 lb. (9 kg).

PVC and PVDF models, 125°F (52°C) maximum.

For Higher Capacities see page 8.

For Higher Capacities and Pressures request Bulletin DP-2000.

For Ultra-Low Capacity High Pressure Models request Bulletin LV.

For Viscous Chemicals and Slurries request Bulletin VP.

For Economy Models request Bulletin DP-500E.



500-S Series and 500-D Series

500-S Series Hydraulic Metering Pumps come standard in the simplex design, but can be converted to a duplex design—500-D Series. This duplex design is configured to include two micrometer dials with two liquid heads.

- Simplex capacities from 0.8 gph (3.02 L/h) to 34 gph (128 L/h)
- Pressures up to 3,000 psi (210 bar)



MODEL 515-S-N3-TEI
with flange adapter



MODEL 525-S-N3



MODEL 535-D-N5

500-S Series and 500-D Series DIMENSIONS

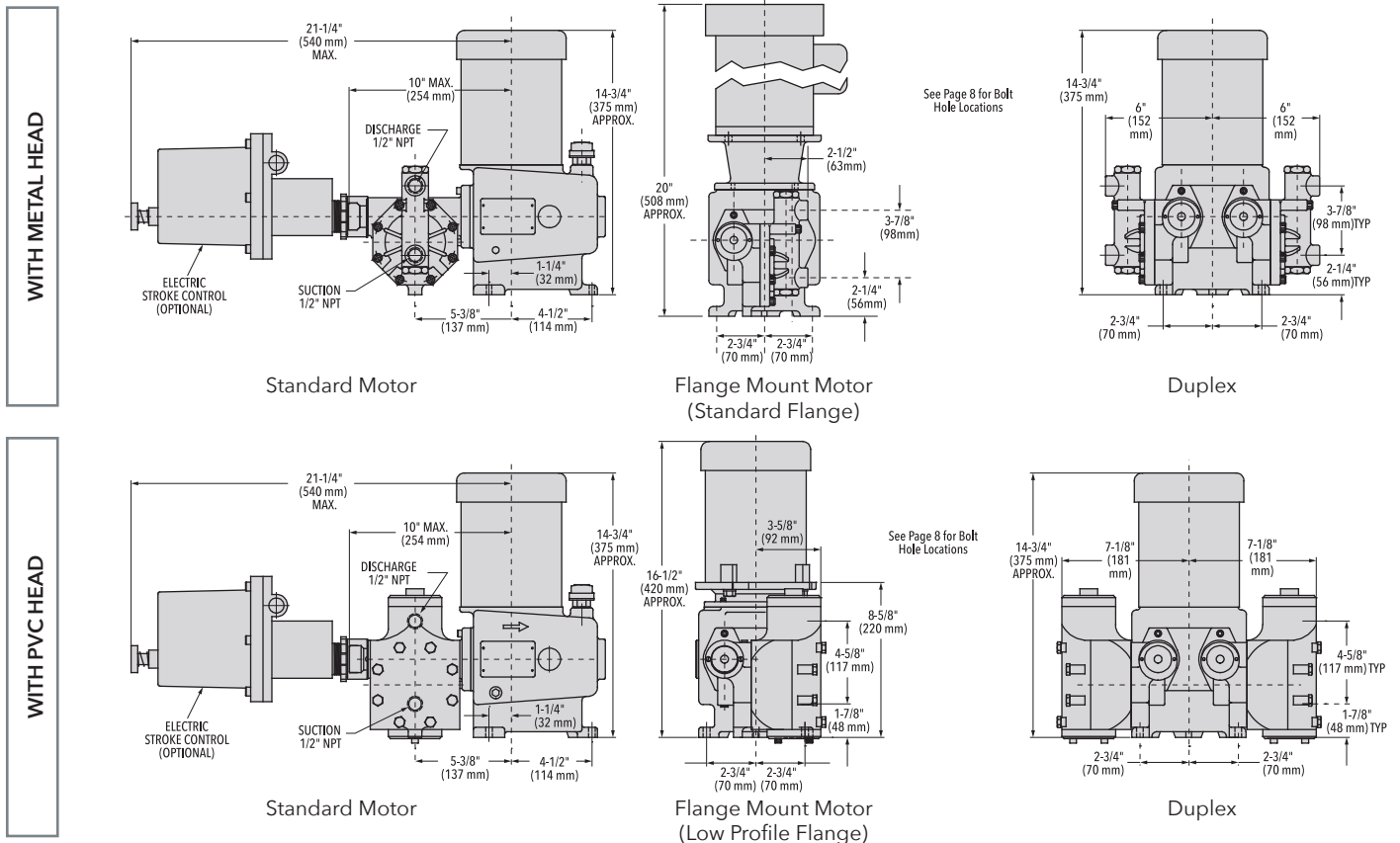

DIMENSIONS ARE APPROXIMATE. SPECIFICATIONS SUBJECT TO CHANGE WITHOUT NOTICE.

500-S Series and 500-D Series SELECTION CHART

Standard Motor: 1/3hp-1ph-115VAC-60c-TEFC†

SIMPLEX AND DUPLEX: Any duplex combination can be created using any models on pages 7 and 8, as long as both have the same stroking speed.

MODEL	PISTON DIAMETER INCHES (MM)	STROKES PER MINUTE AT 60 HZ (50 HZ)	MATERIALS OF CONSTRUCTION	CAPACITY AT 100 PSI (7 BAR) 60 HZ (50 HZ)		MAX PRESSURE				SHIPPING WEIGHT LB. (KG)**
						1/4 HP (0.18 KW) MOTOR OR 1/3 HP (0.25KW) MOTOR		1/2 HP (0.37 KW) MOTOR*		
				GPH	L/H	PSI	BAR	PSI	BAR	
500-S-N3 500-S-N4 500-S-N5	1/2 (13)	37 (31)	316SS C-20 PVC	0.8 (0.7)	3 (2.5)	1,000 1,000 150	70 70 11	3,000 N/A N/A	210 N/A N/A	70 (32)
515-S-N3 515-S-N4 515-S-N5	1/2 (13)	117 (97)	316SS C-20 PVC	3 (2.5)	11.3 (9.4)	1,100 1,100 400	77 77 28	1800 N/A N/A	125 N/A N/A	70 (32)
520-S-N3 520-S-N4 520-S-N5	11/16 (18)	37 (31)	316SS C-20 PVC	2 (1.7)	7.5 (6.3)	700 700 400	49 49 28	N/A N/A N/A	N/A N/A N/A	70 (32)
522-S-N3 522-S-N4 522-S-N5	11/16 (18)	72 (60)	316SS C-20 PVC	4 (3.3)	15.1 (12.6)	700 700 400	49 49 28	N/A N/A N/A	N/A N/A N/A	70 (32)
525-S-N3 525-S-N4 525-S-N5	11/16 (18)	117 (97)	316SS C-20 PVC	7 (5.8)	26.5 (22.1)	900 900 400	63 63 28	1,500 1,500 N/A	105 105 N/A	70 (32)
530-S-N3 530-S-N4 530-S-N5	1-1/16 (27)	37 (31)	316SS C-20 PVC	5.5 (4.6)	20.8 (17.3)	350 350 300	25 25 21	N/A N/A N/A	N/A N/A N/A	70 (32)
532-S-N3 532-S-N4 532-S-N5	1-1/16 (27)	72 (60)	316SS C-20 PVC	11 (9.2)	41.6 (34.7)	350 350 300	25 25 21	600 600 N/A	42 42 N/A	70 (32)
535-S-N3 535-S-N4 535-S-N5	1-1/16 (27)	117 (97)	316SS C-20 PVC	18 (15)	68 (56.7)	350 350 300	25 25 21	600 600 N/A	42 42 N/A	70 (32)
537-S-N3 537-S-N4 537-S-N5	1-1/16 (27)	144 (31)	316SS C-20 PVC	22 (18.3)	83 (69.2)	350 350 300	25 25 21	400 400 N/A	28 28 N/A	70 (32)
547-S-N3† 547-S-N4† 547-S-N5† 547-E-N8† §	1-3/16 (30)	144 (120)	316SS C-20 PVC PVDF	29 (24)	110 (91)	200 200 200 150	14 14 14 11	350 350 300 N/A	25 25 21 N/A	70 (32)
548-S-N3 548-S-N4 548-S-N5 548-S-N8	1-3/16 (30)	176 (146)	316SS C-20 PVC PVDF	28 (23.3)	126 (105)	N/A N/A N/A N/A	N/A N/A N/A N/A	350 350 300 150	24 24 20 10	70 (32)

† Models 547 furnished with integral 1/2hp-1ph-115VAC-TEFC motor as standard. See page 9 for motor options available. IEC metric motor adapter available.

§ See page 6 for gearbox dimensions; see Bulletin DP-500E for PVDF Liquid Head detail. PVDF models do not include Eze-Clean™ valves.

* Neptune recommends that 1/2hp (0.37 kW) high pressure models be used only in flooded suction applications. Flange adapter required for high pressure models.

** Standard motor only. For flanged-mounted motor, add 20 lb. (9 kg).

PVC and PVDF models, 125°F (52°C) maximum.

For Higher Capacities see page 8.

For Higher Capacities and Pressures request Bulletin DP-2000.

For Ultra-Low Capacity High Pressure Models request Bulletin LV.

For Viscous Chemicals and Slurries request Bulletin VP.

For Economy Models request Bulletin DP-500E.

560 Series

560 Series Hydraulic Metering Pumps are designed for higher capacities and available in simplex or duplex design. Our Neptune Simplex design configuration includes a single micrometer dial with one liquid head. Our Neptune Duplex design are configured to include two micrometer dials with two liquid heads.

- Simplex capacities from 40 gph (151.4 L/h) to 94 gph (355 L/h)
- Pressures up to 350 psi (24 bar)



MODEL 567-D-N3



MODEL 562-S-N5

560 Series DIMENSIONS

DIMENSIONS ARE APPROXIMATE. SPECIFICATIONS SUBJECT TO CHANGE WITHOUT NOTICE.

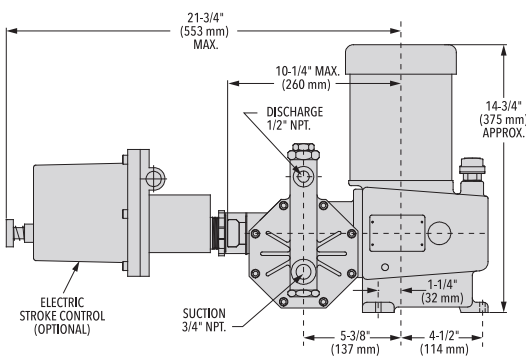

Standard Motor
(Metal Head)

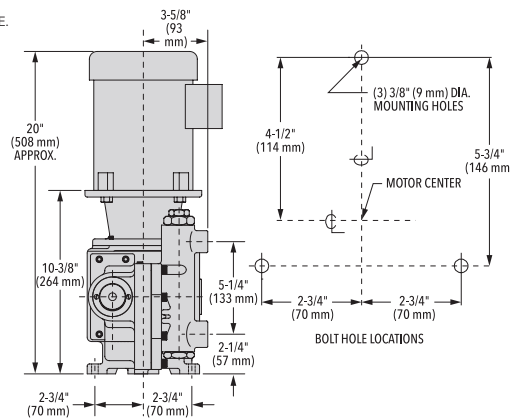

Flange Mount Motor
(Metal Head)

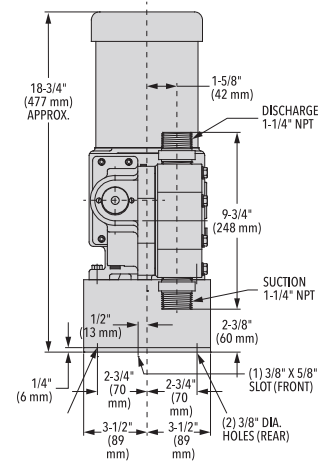

PVC & PVDF Head

560 Series SELECTION CHART

Standard Motor: 1/3hp-1ph-115VAC-60c-TEFC†

SIMPLEX AND DUPLEX: Any duplex combination can be created using any models on pages 7 and 8, as long as both have the same stroking speed.

MODEL	PISTON DIAMETER INCHES (MM)	STROKES PER MINUTE AT 60 HZ (50 HZ)	MATERIALS OF CONSTRUCTION	CAPACITY AT 100 PSI (7 BAR) 60 HZ (50 HZ)		MAX PRESSURE						SHIPPING WEIGHT LB (KG)*
				GPH	L/H	1/2 HP (0.37 KW) MOTOR		3/4 HP (0.56 KW) MOTOR		1 HP (0.75 KW) MOTOR		
						PSI	BAR	PSI	BAR	PSI	BAR	
562-S-N3 562-S-N4 562-S-N5 562-S-N8	2 (51)	72 (60)	316SS C-20 PVC** PVDF**	40 (33)	151 (125)	175	12	250	18	350	25	85 (39)
565-S-N3 565-S-N4 565-S-N5 565-S-N8	2 (51)	117 (97)	316SS C-20 PVC** PVDF**	65 (54)	246 (204)	175	12	250	18	350	25	85 (39)
567-S-N3 567-S-N4 567-S-N5 567-S-N5	2 (51)	144 (120)	316SS C-20 PVC** PVDF**	80 (66)	302 (250)	175	12	250	18	350	25	85 (39)
568-S-N3 568-S-N4 568-S-N5 568-S-N8	2 (51)	176 (146)	316SS C-20 PVC** PVDF**	94 (78)	355 (294)	175	12	250	18	350	25	85 (39)

† For optional motors rated 1/2hp (0.37 KW) and larger, add flange adapter option, plus end mount motor of choice. IEC metric motor adapter available.

* Standard motor only. For flange mounted motor, add 20 lb. (9 kg).

** PVC and PVDF models 150 psi (11 bar) Maximum; 125°F (52°C) Maximum. PVC and PVDF models do not include Eze-Clean™ valves.

For Higher Capacities & Pressures request Bulletin DP-2000.

For Motor Options Available see page 9.

Planning Your Installation

Do not oversize the pump. A metering pump should be sized so the maximum expected flow rate is 80% to 85% of the pump capacity. The minimum capacity should never be planned less than 10% of the pump nameplate rating.

For outdoor applications the pump motor should be sheltered from direct sunlight to prevent overheating. The pump will operate in freezing temperature provided it runs continuously and the liquid being pumped does not freeze.

Consider dust, which can ignite, as well as fumes or vapors when determining if a hazardous environment exists.

Always use a suction strainer 40–60 mesh to prevent foreign matter from clogging the check valves.

Provide suction and discharge isolation valves for maintenance. Select large port, quick opening valves.

Calibration Column—a suction draw down column is the most accurate and convenient method to measure pump performance.

Relief Valve—the internal relief valve furnished with these pumps is

to protect the pump. Provide an external relief valve to protect the system piping.

Back pressure valves—required when the system does not provide sufficient back pressure. Do not depend on a spring-loaded check valve when feeding from bulk tanks to a low-pressure application where the discharge is below the tank.

Pulsation dampener—used when long discharge runs (between the pump and injection point) need dampening to reduce water-hammer or pressure spikes caused by acceleration in the discharge line.

Suction Piping—keep the piping as short as possible, minimizing bends, elbows and other restrictions. The safest rule of thumb is to use piping one size larger than the pump suction connection. Piping may be the same size as pump suction connection for slow speed pumps used with low viscosity chemicals.

Feel free to contact the Neptune factory for application assistance.

For additional information, refer to the “Sizing and Selecting Metering Pumps” Guide with complete information about planning and installation.

Notes

1. MOTORS:

500 Series Hydraulic Metering Pumps are supplied with an integrally mounted 1/3hp-1ph-60c 115VAC-TEFC motors as standard (1/2hp for 560 Series). This motor is provided with automatic thermal overload protection.

Pumps may be ordered, less motor, with flange adapter. Specify as follows:

Add Suffix “FA” to model number to specify NEMA 56C motor adapter (Standard Flange).

Add Suffix “FALP” to model number to specify NEMA 56C motor adapter (Low Profile).

Add Suffix “FALP-D71” to specify adapter for D71 IEC motor adapter.

Add Suffix “FALP-D80” to specify adapter for D80 IEC motor adapter.

Stock motor options available as follows:

A. Integrally Mounted 1/2hp-1ph-60c-115VAC-TEFC—
Add Suffix “2” to model number.

Integrally Mounted 1/2hp-3ph-60c-230/460VAC-TEFC—
Add Suffix “3” to model number.

Integrally Mounted 1/3hp-1ph-50c-110/220VAC-TEFC—Add
Suffix “251” to model number.

Integrally Mounted 1/2hp-1ph-50c-110/220VAC-TEFC—
Add Suffix “371” to model number.

Integrally Mounted 1/2hp-3ph-50c-190/220/380-440VAC-
TEFC—Add Suffix “373” to model number.

B. Explosion-Proof Motors—Flange Mounted (Class I, Groups C & D; Class II, Groups E, F & G Hazardous Locations)

1/3hp-1ph-60c-115/230VAC-Explosion-Proof—Add Suffix
“EX1” to model number.

1/3hp-3ph-60c-230/460VAC-Explosion-Proof—Add Suffix
“EX3” to model number.

C. Totally Enclosed Fan-Cooled Motors—Flange Mounted
1/3hp-1ph-60c-115/230VAC-TEFC—Add Suffix “TE1” to
model number.

1/3hp-3ph-60c-230/460VAC-TEFC—Add Suffix “TE3” to
model number.

D. Severe-Chemical Duty Motors—Flange Mounted
1/3hp-1ph-60c-115/230VAC-TENV-Class F, 1.15 service
factor—Add Suffix “SXT1” to model number.

1/3hp-3ph-60c-230/460VAC-TENV-Class F, 1.15 service
factor—Add Suffix “SXT3” to model number.

2. CAPACITY:

Capacity figures are listed at 100 psi (7 bar) discharge pressure, based on water using 1725 rpm (60 Hz) motor. Capacity will decrease by approximately 1.5% for each 100 psi (7 bar) increase in pressure.

A. IEC 50 Hz operation (1425 rpm) motor adapter.

3. ACCURACY:

Accuracy is $\pm 1\%$ of full scale over the range of 10% to 100% of capacity.

4. TEMPERATURE AND VISCOSITY:

Contact factory for temperatures over 200°F (93°C) or viscosity greater than 1000 centipoise.

For additional information, refer to the “Sizing and Selecting Metering Pumps” Guide with complete information about planning and installation.

Double Diaphragm With Leak Detection

Neptune offers a double diaphragm leak detection option for applications where contamination of the process fluid by the pump hydraulic fluid cannot be tolerated or where diaphragm failure must be sensed immediately.

The Neptune double diaphragm design uses two "dry" coupled diaphragms. The area between the diaphragms is evacuated. Hydraulic pumping action is transmitted from one diaphragm to the other without the use of any intermediate fluids.

The diaphragm condition is monitored by a pressure switch which can be wired to shut off the pump and/or sound a remote alarm. This design eliminates conductivity probes which could fail to detect the presence of oil or low conductivity liquids in the event of a diaphragm failure.

The double diaphragm option "DD" is available on all Neptune hydraulic metering pumps above 520.

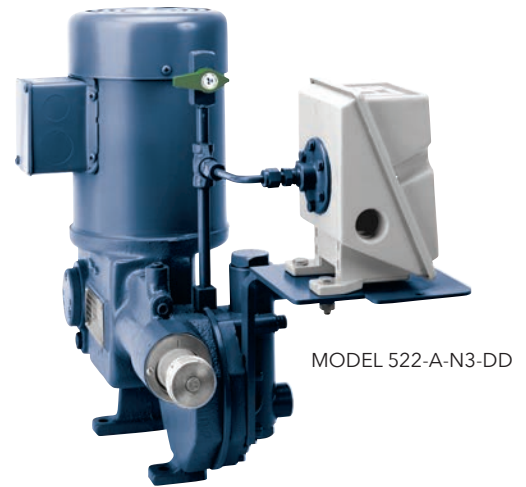

MODEL 522-A-N3-DD

Automatic Control and Other Features

SODIUM HYPOCHLORITE GAS BLEED

Special head designed with an automatic air release valve to vent gas accumulation from chemicals that emit gas, such as sodium hypochlorite.



ELECTRIC STROKE CONTROL

The flow rate of any Neptune hydraulic metering pump can be controlled automatically by a process instrument, or manually from a remote location, using the Electric Stroke Control to adjust stroke length. The Neptune Electric Stroke Control is a one-piece, self-contained Electric Positioner mounted on the pump.

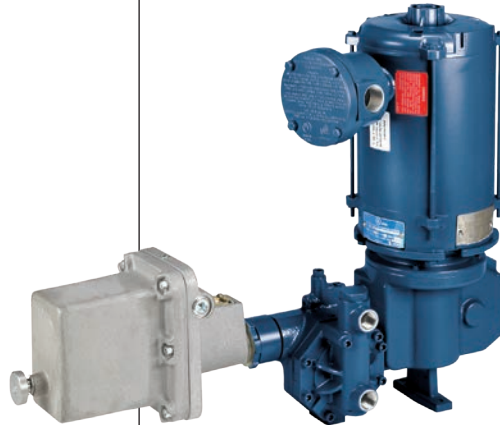

- 60/50 Hz, 110/220 V
- Explosion-proof motors available
- Unit follows 4-20 mA or 1-5V signal
- Adjustable ratio signal to stroke 1:2 or 2:1
- Direct (forward) or indirect (reverse) response to changing signal
- Manual override in event of instrument signal or power loss

Note: Can be added on only one head of duplex pumps.

CE MARK - IEC MOTORS

All pumps are CE compliant and feature a CE label when coupled to a motor bearing the CE mark. In addition to integrally-mounted NEMA motors, the following integral or "canned" motor options are available in IEC configurations with CE mark:



- 1/3hp (0.25 kW) - 1ph-50c-110/220VAC-TEFC IP54 1425 RPM
- 1/2hp (0.37 kW) - 1ph-50c-110/220VAC-TEFC IP54 1425 RPM
- 1/2hp (0.37 kW) - 3ph-50c-190-220/380-440VAC-TEFC IP54 1425 RPM

All pumps can be furnished with a metric flange adapter to accommodate a D71 motor from 0.25 kW through 0.55 kW. Pumps requiring 0.75 kW and larger can be furnished with a flange adapter for D80 motor.

VARIABLE SPEED CONTROL

The flow rate of any Neptune hydraulic metering pump can be controlled automatically by a process instrument using a variable speed drive to change pump stroke speed. Optional motor flange adapter allows convenient mounting of any AC or DC variable speed motor control package.

Note: Select pump with stroking speed sufficiently high that, at minimum speed, pump operates at 15 spm minimum.



Additional Solutions by Neptune

BACK PRESSURE VALVES

Back pressure valves are adjustable to a maximum of 50 psi (3.5 bar). Ensure the set pressure is maintained at the pump outlet port (discharge) to assure accurate metering and prevent siphoning. Required accessory when pumping to a low-pressure injection point below the tank level or when pumping from a bulk tank with a high head pressure.



- Available in PVC, 316SS, PVDF and C-20 materials
- Standard sizes include 1/2" through 1-1/2" options

CALIBRATION COLUMNS

Provide a fast, easy economical way to check the flow rate of a chemical metering pump.



- Standard sizes include 100, 250, 500, 1000 and 4000 ml options
- May be used with any 500-E Series or Electronic Metering Pumps

CORPORATION STOPS WITH INJECTION QUILLS AND HIGH-PRESSURE INJECTION QUILLS

Corporation Stops with Injection Quills are used for injecting chemicals pumped by metering pumps into tanks, mains, cooling towers and process systems. High Pressure Injection Quills are used to inject chemicals pumped by metering pumps into the turbulent flow zone of high pressure water or steam lines.



- Available in CPVC, PVDF, 316SS and C-20 materials

PRESSURE RELIEF VALVES

Relief valves protect piping and system from overpressure.



- Available in PVC, 316SS, PVDF and C-20 materials
- Standard sizes include 1/2" through 1-1/2" options

EZE-GRAB PLATFORM

Molded polyethylene base provides elevated platform for use indoors or outdoors. Handles allow the pump to be moved easily.



- May be used with 500-S, 500-D, 500-A, 500-E, or 560 pumps

SAMPLE COOLERS

Cool hot water or steam samples for easy handling and effective sample collection. Suitable for use on hot water, saturated steam or super-heated steam services.



- Available in 316SS and Inconel materials

PULSATION DAMPENERS

Remove the pulsating flow caused by a pump's reciprocating action, ensuring a smooth, laminar flow.



- Available in PVC, polypropylene, 316SS, and C-20 (with FKM or EPDM bladders) materials

30 GALLON MINI TANK

Neptune offers a line of completely packaged chemical feed systems, with or without containment.



- May be used with any 500-A Series, 500-E Series or Electronic Metering Pumps

BY-PASS FEEDERS

Neptune By-Pass Feeders are a convenient method of introducing treatment chemicals into closed water recirculation systems. Neptune By-Pass Feeders are ideal for treating hot and chilled closed water recirculation loops used in heating and air conditioning systems, process heating and cooling or large engine water jackets.



- Available with and without legs
- Max pressure up to 300 psi (20.7 bar)

For more information on these additional solutions, visit us at psgdoover.com/neptune.



PSG
22069 Van Buren Street
Grand Terrace
CA, 92313-5651
USA
P: +1 (909) 422-1730
F: +1 (909) 783-3440
psgdover.com/neptune



Where Innovation Flows

DP-1100-19

NPT-10010-C-02

Authorized PSG® Partner:

Copyright 2019 PSG®, a Dover company