

# JGT Series Bulk Container Mixer

Gear Drive, Bung or Bracket Mount, 350 rpm

## FEATURES AND BENEFITS

- Mounts to the tank or optional universal bracket
- 316SS propeller folds to fit through 2" (50.8 mm) opening; opens to 9" (228.6 mm) operating diameter
- Standard useable length is 33" (838.2 mm) / overall 35.5" (901.7 mm)

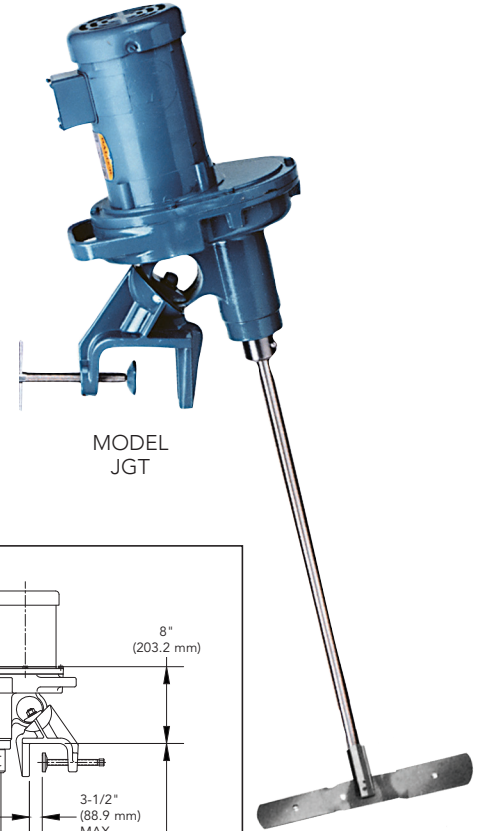

MODEL JGT

MODEL	STANDARD MOTOR DESCRIPTION	DIMENSIONS INCHES (MM)
		SHAFT DIAMETER
<b>TOTALLY-ENCLOSED, FAN-COOLED (TEFC) AND EXPLOSION PROOF (EP)</b>		
JGT-3.0	1/2HP-1-115/230-TEFC	1 (25.4)
JGT-3.1	1/2HP-3-230/460-TEFC	1 (25.4)
JGT-3.2	1/2HP-1-115/230-EP	1 (25.4)
JGT-3.3	1/2HP-3-230/460-EP	1 (25.4)
JGT-4.0	3/4HP-1-115/230-TEFC	1 (25.4)
JGT-4.1	3/4HP-3-230/460-TEFC	1 (25.4)
JGT-4.2	3/4HP-1-115/230-TEFC	1 (25.4)
JGT-4.3	3/4HP-3-230/460-EP	1 (25.4)
JGT-5.1	1HP-3-230/460-TEFC	1 (25.4)
JGT-5.3	1HP-3-230/460-EP	1 (25.4)
<b>AIR MOTOR</b>		
JGT-3.4	1/2HP - AIR REQUIREMENTS - 20 CFM (0.57 CMM) AT 40 PSI (2.8 BAR)	1 (25.4)
JGT-5.4	1HP - AIR REQUIREMENTS - 40 CFM (1.13 CMM) AT 40 PSI (2.8 BAR)	1 (25.4)

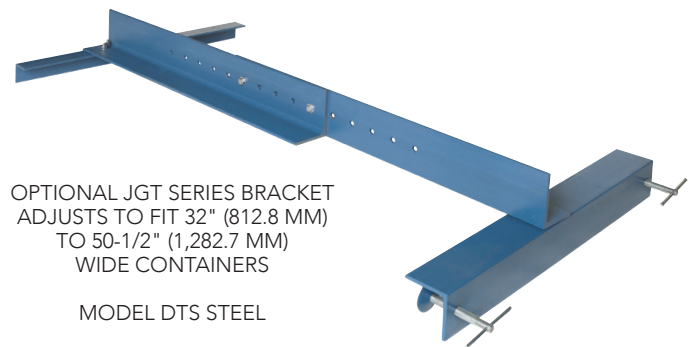
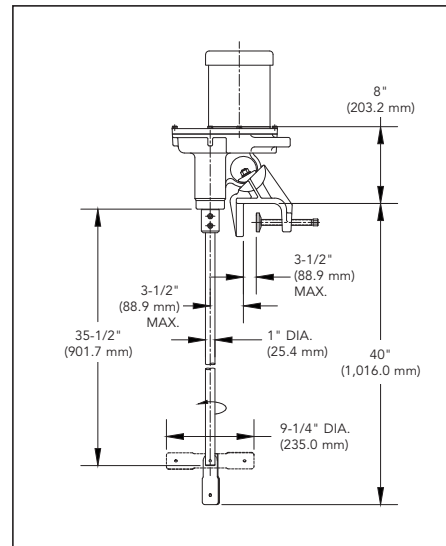

OPTIONAL JGT SERIES BRACKET  
 ADJUSTS TO FIT 32" (812.8 MM)  
 TO 50-1/2" (1,282.7 MM)  
 WIDE CONTAINERS

MODEL DTS STEEL



Missouri Filter & Process Equipment Co  
 MOFILCO-Quality, Value, Service  
 12025 Manchester Road, Suite 30G  
 St Louis MO 63131

314-821-4321 www.mofilco.com  
 mofilco@mofilco.com

# Bulk Container Mixer

Gear Drive, Bung or Bracket Mount

Neptune bulk container mixers allow mixing in semi-bulk shipping containers.

## HGL Series, 430 rpm

### FEATURES AND BENEFITS

- Mounts to 2" (50.8 mm) coupling or flange
- 316SS propeller folds to fit through 2" (50.8 mm) opening; opens to 9" (228.6 mm) operating diameter
- Second folding propeller bolts anywhere on 3/4" (19.1 mm) shaft – P/N 004479

MODEL	STANDARD MOTOR DESCRIPTION	DIMENSIONS INCHES (MM)
		SHAFT DIAMETER
<b>TOTALLY-ENCLOSED FAN-COOLED (TEFC)</b>		
HGL-3.0	1/2 HP-1-115/230	3/4 (19.1)
HGL-5.0	3/4 HP-1-115/230	3/4 (19.1)
HGL-6.0	1 HP-1-115/230	3/4 (19.1)
HGL-6.2	1 HP-3-230/460	3/4 (19.1)
<b>AIR MOTOR</b>		
HGL-4.0	1/2 HP AIR REQUIREMENTS: 20 CFM (0.57 CMM) AT 40 PSI (1.4-2.8 BAR)	3/4 (19.1)
HGL-7.0	3/4 HP - 1 HP AIR REQUIREMENTS: 30-40 CFM (0.85-1.13 CMM) AT 25-35 PSI (1.7-2.4 BAR)	3/4 (19.1)

For explosion-proof models, see price list.

## RGT Series, 350 rpm

### FEATURES AND BENEFITS

- Mounts to the tank or optional bracket
- 316SS propeller folds to fit through 2" (50.8 mm) opening; opens to 9" (228.6 mm) operating diameter
- Second folding propeller bolts anywhere on 3/4" (19.1 mm) shaft – P/N 004479

MODEL	STANDARD MOTOR DESCRIPTION	DIMENSIONS INCHES (MM)
		SHAFT DIAMETER
<b>TOTALLY-ENCLOSED FAN-COOLED (TEFC)</b>		
RGT-1.0	1/2 HP-1-115/230	3/4 (19.1)
RGT-1.2	1/2 HP-3-230/460	3/4 (19.1)
RGT-2.0	3/4 HP-1-115/230	3/4 (19.1)
RGT-2.2	3/4 HP-3-230/460	3/4 (19.1)
RGT-3.0	1 HP-1-115/230	3/4 (19.1)
RGT-3.2	1 HP-3-230/460	3/4 (19.1)
<b>AIR MOTOR</b>		
RGT-1.4	1/2 HP AIR REQUIREMENTS: 20 CFM (0.57 CMM) AT 40 PSI (1.4-2.8 BAR)	3/4 (19.1)
RGT-3.4	3/4 HP - 1 HP AIR REQUIREMENTS: 30-40 CFM (0.85-1.13 CMM) AT 25-35 PSI (1.7-2.4 BAR)	3/4 (19.1)

For explosion-proof models, see price list.

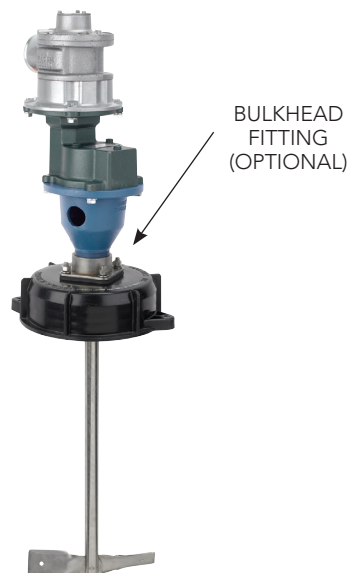
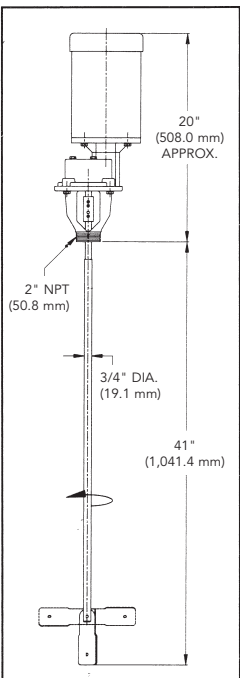

HGL SERIES MIXER WITH CAP MOUNT CONVERTS ANY POLY CAP TO A 2" (50.8 MM), 316SS, THREADED, FEMALE FITTING TO MOUNT THE HGL MIXER. SPECIFY BULKHEAD FITTING (OPTIONAL)

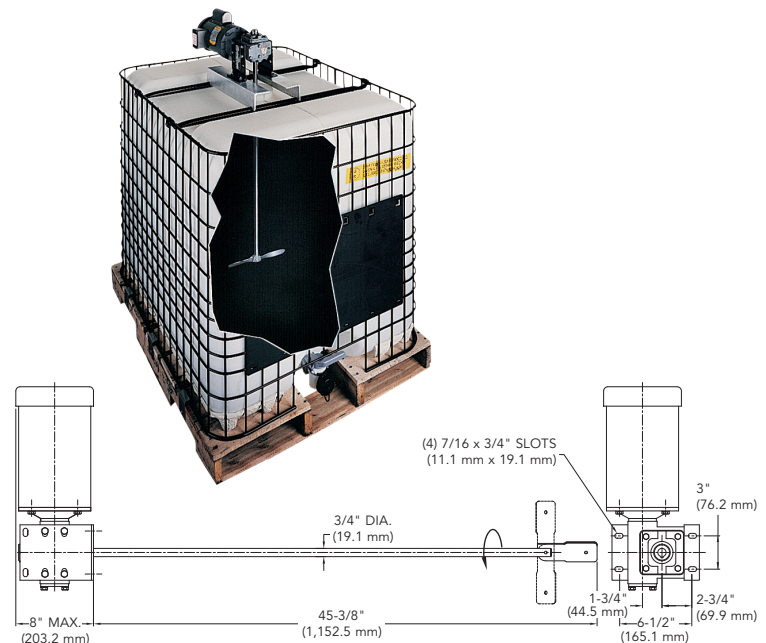

# RGT Mixers

Use Series RGT mixers on single containers or containers sandwiched between stacked semi-bulk shipping containers.

RGT MIXER  
INSTALLED BETWEEN  
STACKABLE IBCS

