



POLYETHYLENE TANKS AND ACCESSORIES

QUALITY: FIRST AND FOREVER

IT TAKES TIME
TO MAKE SOMETHING
THAT LASTS.

Assmann polyethylene bulk storage tanks are built the right way – even if that's not the easiest or fastest way. We're the only manufacturer who uses non-shielded molds with low temperature heat and gradual air cooling. The result is truly uniform wall thickness, unparalleled certified quality, and reliability that proves itself every time and across decades.



Contents:

ASSMANN QUALITY	1	ACCESSORIES AND ADD-ONS	21
Our Process	1	Flange Fittings	23
5-year Warranty	2	Bulkhead Fittings	24
Certifications	3	316 Stainless Steel Fittings	25
POLYETHYLENE TANKS	5	PVC Self-Aligning Dome Fittings	26
Vertical Storage Tanks	7	Polyethylene Welded Connections for Linear Tanks	27
Double Wall Vertical Storage Tanks	9	Vent Assemblies	27
Small Double Wall Vertical Storage Tanks	10	Fill Line / Suction Line Assemblies	28
Chemical Feed Stations	11	Anti-Foam Elbow	29
Conical Bottom Storage Tanks	12	Sight Gauge Assemblies	29
Cylindrical Horizontal Tanks	13	Reverse Float Level Indicator	30
Free-Standing Horizontal Leg Tanks	14	Leak Detection System	30
Open Top Tanks	15	Restraint Tie-Down and Lifting Lugs System	31
Double Wall Base Containers	16	Tank Heat Tracing and Insulation	32
Industrial Mini Bulk and Mini Drum Tanks	16	Fiber-Reinforced Ladder Assemblies	33
Rectangular Secondary Containment Basins	18	Agitator Support Brackets for Vertical and Conical Tanks	34
Cylindrical Secondary Containment Basins	19	YOUR PRE-QUOTE CHECKLIST	35
		ASSMANN PRODUCT RATINGS AND TEMPERATURE PERFORMANCE	37



**A TANK YOU
CAN COUNT
ON. EVERY
SINGLE TIME.**



How We Build Quality into Each Assmann Tank

It might take a little more time and effort, but we'll never abandon successful production methods for cost-cutting measures. That means every single time, you get a tank you can count on for years—even decades. Here's how we do it:

1. ROTATIONAL MOLDING SETS THE STAGE

A stationary furnace provides convection heat to our unique and efficient large ovens, which rotate end-over-end. The oven shape and foil design create optimum airflow and uniform heat to set the foundation for the highest quality parts possible.

We opt for temperatures that rarely exceed 500° F in the molding process. Why? Using higher temperatures speeds up the cycle time but can ultimately compromise the final product, particularly in XLPE and thicker wall parts.

2. GRADUAL COOLING FOR STRUCTURAL INTEGRITY

We introduce zero water into the cooling cycle. Once molded, Assmann tanks are placed in separate chambers and subject to very high volume air movement. This allows the mold and the tank inside to cool gradually while the cross-linking process continues all the way through the tank wall, strengthening the whole structure and lengthening its lifespan.

Even in 1.45" thick walls, Assmann tanks consistently attain cross-linking test results between 75% and 85%, well above the minimum standard of 60%.

3. NO SHIELDING. EVER.

Within the tank manufacturing industry, it's become common practice to wrap and weld layers of sheet metal around the outside of the mold to reduce heat transfer. This shielding causes reduced upper and lower sidewall thickness—sometimes by up to 25%—making the tank more vulnerable to stress and failure.

Because Assmann tanks are air-cooled, the cross-linking takes place gradually. We never shield the outside of our tank molds. This alleviates a large portion of process-related stress. Throughout our process, we exceed ASTM design hoop stress minimums and achieve more uniform wall thickness for maximum structural integrity.

The Assmann 5-Year Warranty

We stand by our quality with pride and confidence. That's why every Assmann tank you purchase includes a 5-year warranty. That means Assmann warrants our tanks to be free from defects in workmanship and materials, under normal use and service, to the original purchaser for a period of 5 years from the date of shipment from our factory.

Installation and operation must comply with all applicable federal, state, and local regulations, and must be in accordance with applicable instructions and limitations contained in the Assmann Usage and Handling guidelines for the tank.

WARRANTY SHALL NOT APPLY TO ANY PRODUCT THAT AFTER LEAVING OUR FACTORY:

1. Has been repaired or altered in any manner not authorized by Assmann
2. Has been subject to abuse, misuse, fire, accident, neglect, or improper handling
3. Has not been used in accordance with Assmann chemical resistance charts
4. Has been exposed to pressures greater than atmospheric pressure
5. Has been exposed to internal or external temperatures greater than 120°F (for linear polyethylene) or 150°F (for cross-link polyethylene)
6. Has been connected, installed, adjusted, or used otherwise than in accordance with the instructions provided by Assmann

Assmann's sole liability and our customers' sole remedy shall be limited to the warranties contained within the exclusive warranty. Under no circumstances shall Assmann be liable for special, indirect, incidental, punitive, or consequential damages resulting from the performance or operation of any product manufactured or sold by Assmann. To see a full copy of Assmann Corporation of America's exclusive warranty, talk to your Assmann team.



ISO Certification



The first and only polyethylene manufacturer to achieve ISO 9001:2015 certification.

ISO 9001 is the original quality management standard and the world's most widely recognized quality management system certification. Attaining ISO 9001:2015 certification isn't a one-time achievement; it's a high bar we have to continually meet.

To continue to earn this distinction, we must continually prove—and improve—our capabilities to provide products and services that meet and exceed customer expectations.

Our entire staff monitors each individual stage of our manufacturing process for errors and areas for improvement, instead of just inspecting the final product.

Each tank we produce has its own quality control and routing card that links the product back to its manufacture date, raw material lot numbers, and processing times. This level of traceability is critical, especially for government-regulated bulk chemical storage.

INTERNATIONAL ORGANIZATION FOR STANDARDIZATION (ISO)

ISO is a family of standards for quality management systems. The organization audits engineering and manufacturing processes for effectiveness and continuous improvement.

NSF Certification



Assmann polyethylene tanks are the first to be NSF Certified for chemical storage.

Assmann cross-linked polyethylene tanks are certified by NSF to ANSI 61 standards for chemical storage, which ensures our products do not contribute contaminants to drinking water that could cause adverse health effects.

Our unique cross-link resin is certified for many chemical applications, including sodium hypochlorite, sulfuric acid, and sodium hydroxide.

Additionally, Assmann linear polyethylene tanks are certified by NSF to ANSI 61 standards for potable water.

NATIONAL SANITATION FOUNDATION (NSF)

National Sanitation Foundation (NSF) International certifies products that have been rigorously tested to comply with public health standards, particularly to help protect the world's food, water, consumer products, and environment.

Assmann Polyethylene Tanks

Assmann polyethylene tanks are constructed from scratch, and designed to outlast the competition at every turn. Our tanks are used for above-ground bulk storage of chemicals, petroleum products, wastewater, food processing, agriculture liquids, pharmaceutical liquids, and more. No matter what your final application is, you can trust that your Assmann tanks are built right and built to last.

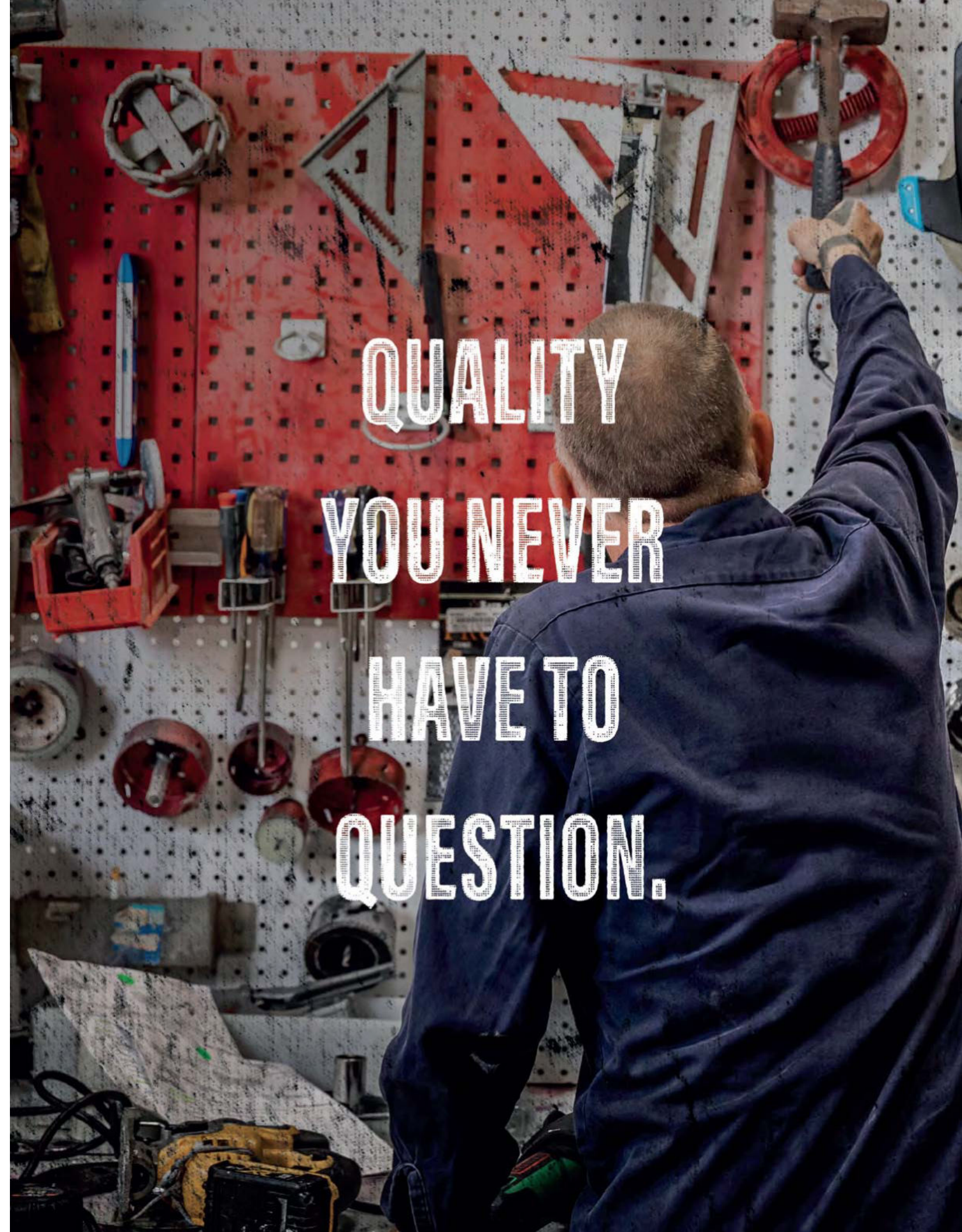

QUALITY
YOU NEVER
HAVE TO
QUESTION.



Vertical Storage Tanks



Assmann vertical storage tanks are rotationally molded from your choice of virgin high-density cross-linked polyethylene or FDA-compliant linear polyethylene. Both are more corrosion- and chemical-resistant than fiberglass, stainless steel, and mild steel.

All Assmann vertical storage tanks possess excellent low-temperature impact resistance and UV stabilization.

- **Semi-translucent and seamless**, with gallon markers and access openings built in
- **Wall thickness conforms to ASTM D-1998** standards for liquid storage
- **Narrow tank diameters** save space in your plant
- **Choose from a variety of colors** and accessories to fit your needs

Model Number	Capacity (US Gallons)	Dimensions (Inches)		Weight (lbs) Linear and Crosslink Polyethylene				Access Opening (Inches)
		Diameter	Height	1.35 Sp. Gravity	1.5 Sp. Gravity	1.9 Sp. Gravity	2.2 Sp. Gravity	
ICT 40	40	20	38	N/A	N/A	20	N/A	16
ICT 60	60	23	42	N/A	N/A	28	N/A	16
ICT 65	65	23	44	N/A	N/A	28	N/A	7
ICT 80	80	24	49	N/A	N/A	30	N/A	16
ICT 120	120	29	52	N/A	N/A	50	N/A	7
ICT 140	140	29	58	N/A	N/A	50	N/A	16
ICT 175	175	35	51	N/A	N/A	56	N/A	16
ICT 200 (35")	200	35	57	N/A	N/A	64	N/A	16
ICT 200 (36")	200	36	53	N/A	N/A	60	N/A	16
ICT 250	250	35	69	N/A	N/A	75	N/A	16
ICT 300	300	35	82	N/A	N/A	85	115	16
ICT 400	400	48	63	N/A	N/A	99	120	16
ACT 550	550	69	43	N/A	N/A	120	120	16
ICT 550	550	48	82	N/A	130	130	160	16
IFT 550	550	48	83	N/A	130	130	160	11
IFT 600	600	48	83	140	140	160	177	11
ICT 625	625	48	93	N/A	N/A	140	175	16
ICT 700	700	69	58	N/A	130	150	175	16
ICT 850	850	48	120	166	180	230	267	16
IFT 950	950	64	83	171	190	205	240	11
ICT 1000	1000	64	84	171	190	205	240	16
ICT 1100	1100	86	66	171	190	220	260	16
ICT 1200	1200	64	100	203	260	330	350	16
ACT 1500	1500	86	74	227	250	320	420	16
ICT 1500	1500	64	121	295	320	415	480	16
ICT 1850	1850	96	78	335	350	400	605	16
ICT 2000	2000	86	100	335	375	430	665	16
ICT 2050	2050	64	165	450	500	620	800	16
ICT 2400	2400	96	95	412	450	620	800	16
ICT 2500	2500	86	119	441	450	620	808	16
ICT 2900	2900	96	111	568	620	800	990	16
ICT 3000	3000	90	122	568	620	800	1035	16
ICT 4000	4000	90	162	782	850	1100	1620	16
ICT 4100	4100	119	108	782	850	1100	1400	24*
ICT 4200	4200	96	152	782	850	1100	1620	16
ICT 5200	5200	105	160	1101	1200	1550	1895	24*
ICT 5500	5500	119	141	1215	1350	1600	2200	24*
ICT 5600	5600	96	196	1350	1500	1750	2600	24*
ICT 6500	6500	105	193	1776	1900	2500	2850	24*
ICT 6510	6510	119	163	1575	1750	2000	2450	24*
ICT 7300	7300	119	177	2028	2244	2866	3299	24*
ICT 8000	8000	143	142	1989	2200	2800	3250	24*
ICT 8410	8410	119	201	2758	3065	3882	4495	24*
ICT 10000	10000	143	173	2700	3000	3400	4770	24*
ICT 12000	12000	143	196	3400	3800	4400	5340	24*
ICT 12500	12500	143	214	4300	4773	6075	7022	24*

*All 24" manway access covers are hinged. Model number availability and individual specifications subject to change without notice. Gallonage and weights are approximate. All wall thicknesses conform to ASTM D-1998.

Double Wall Vertical Storage Tanks



Double wall tanks provide the best protection against hazardous chemical spills into the environment. Inside each tank, an inner dome overlaps the outer sidewall to help prevent rainwater, snow, and debris from entering the containment basin. Heat tracing and insulation accessories make these tanks perfect for temperature-sensitive chemicals.

- **Outlet Options:** Either top suction or flooded suction options available
- **Wall thickness equal to or greater than ASTM D-1998 standards**
- **Customizable assembly options available:** seismic and wind load tie downs, leak detection, ultrasonic level indicators, and ladders



Model Number	Cap. (US Gals)	Dimensions (Inches)		Weight (lbs) Linear Polyethylene						Weight (lbs) Crosslink Polyethylene						Access Open. (In)
		Dia.	Hgt.	Primary Sp. Gravity			Secondary Sp. Gravity			Primary Sp. Gravity			Secondary Sp. Gravity			
IMT 550	550	60	73	N/A	130	159	N/A	130	151	N/A	130	159	N/A	130	159	16
IMT 625	625	47	113	117	152	176	127	162	191	117	152	176	127	162	191	16
IMT 1050	1050	72	87	185	205	233	191	244	283	185	205	226	176	221	256	16
IMT 1550	1550	72	123	325	408	472	309	392	454	297	380	440	283	359	416	16
IMT 2050	2050	72	159	551	691	809	596	748	875	505	633	738	545	697	799	16
IMT 2100	2100	123	72	380	478	563	402	509	509	352	450	521	362	469	536	16
IMT 2550	2550	96	119	643	823	953	499	632	732	600	748	866	457	579	671	16
IMT 3050	3050	96	138	817	1022	1183	694	879	1018	739	944	1093	636	806	933	16
IMT 4050	4050	96	177	1252	1607	1870	1178	1492	1728	1158	1476	1700	1178	1492	1728	16
IMT 4400	4400	123	121	1143	1444	1685	1208	1525	1782	1043	1324	1544	1109	1406	1624	16
IMT 5250	5250	119	154	1484	1920	2225	1342	1699	1968	1372	1753	2025	1230	1558	1804	16
IMT 6550	6550	119	186	2181	2778	3200	2028	2569	2974	2000	2570	2960	2028	2569	2974	16
IMT 8850	8850	143	173	3112	3942	4565	3209	4065	4706	2853	3614	4184	2942	3726	4314	24

Model number availability and individual specifications subject to change without notice. Gallonage and weights are approximate. All wall thicknesses conform to ASTM D-1998.

Small Double Wall Vertical Storage Tanks



Our small double wall tanks include a primary inner chamber and a secondary outer chamber at 120% of the inner tank size. This balance exceeds EPA standards and complies with 40 CFR-264.193.

- **Ideal for outdoor chemical storage** because inner tank dome overlaps outer sidewall to help prevent rainwater, snow, and debris from entering
- **7" threaded top access opening** is chemically resistant and fume-tight. Larger openings are also available
- **Most models fit through standard 36" doorway** to allow convenient placement, even in tight areas
- **Molded-in pump shelf** is ideal for installing chemical pumps and metering equipment; the pump shelf is recessed to contain small chemical spills
- **Recessed lower fitting allows for full-flooded suction** for outlet assemblies. It allows fittings to penetrate through the secondary containment wall and into the primary tank's sump
- **Interstitial leak detection systems option available**

Model Number	Cap. (US Gals)	Dimensions (Inches)		Weight (lbs) Linear Polyethylene						Weight (lbs) Crosslink Polyethylene						Access Open. (In)
		Dia.	Hgt.	Primary Sp. Gravity			Secondary Sp. Gravity			Primary Sp. Gravity			Secondary Sp. Gravity			
IMT 20	20	26 1/8	21 3/8	N/A	17	N/A	N/A	17	N/A	N/A	17	N/A	N/A	17	N/A	7
IMT 40	40	26 1/8	33 1/2	N/A	26	N/A	N/A	26	N/A	N/A	26	N/A	N/A	26	N/A	7
IMT 65	65	26 1/8	47 3/4	N/A	36	N/A	N/A	36	N/A	N/A	36	N/A	N/A	36	N/A	7
IMT 85	85	34 1/2	38 1/2	N/A	45	N/A	N/A	45	N/A	N/A	45	N/A	N/A	45	N/A	7
IMT 120	120	34 1/2	51	N/A	56	N/A	N/A	56	N/A	N/A	56	N/A	N/A	56	N/A	7
IMT 150	150	47	44	N/A	65	N/A	N/A	65	N/A	N/A	65	N/A	N/A	65	N/A	7/16
IMT 165	165	34 1/2	66	N/A	69	N/A	N/A	69	N/A	N/A	69	N/A	N/A	69	N/A	7
IMT 250	250	47	61	N/A	95	N/A	N/A	95	N/A	N/A	95	N/A	N/A	95	N/A	7/16
IMT 405	405	47	76	N/A	74	82	N/A	77	90	N/A	74	77	N/A	77	82	7/16

Model number availability and individual specifications subject to change without notice. Gallonage and weights are approximate. All wall thicknesses conform to ASTM D-1998.



Molded-in sump in the primary tank is located directly below the pump shelf. Suction lines can be lowered onto the sump area, which will allow for maximum drainage of chemical with top discharge assemblies.



Inner tank dome overlaps outer tank to prevent contamination.

Molded-in pump shelf is recessed in the top of the tank. Shown with optional metering pump.



Chemical Feed Stations



Our complete, ready-to-use chemical feed stations (CFS) allow you to handle small amounts of liquids and other chemicals without the handling costs and inconvenient disposal of drums. Each station is constructed from high-density cross-link polyethylene or FDA-compliant linear polyethylene, and the final result is lightweight, easy to handle, and self-contained. You can add on features such as molded pump shelves, polyethylene primary tank stands, custom design fittings, and accessories according to your needs.

Model Number	Capacity (US Gallons)	Length	Dimensions (Inches)		Access Opening (Inches)
			Width	Height	
CFS 40	40	32	26	38	16
CFS 60	60	47	32	42	16
CFS 80	80	47	32	49	16
CFS 140	140	52	38	58	16
CFS 175	175	60	43	51	16
CFS 200	200	60	43	57	16
CFS 250	250	72	43	69	16
CFS 300	300	72	43	82	16
CFS 550	550	83	64	82	16

Model number availability and individual specifications subject to change without notice. Gallonage and weights are approximate. All wall thicknesses conform to ASTM D-1998.



Optional fiberglass shelves are available for pumps and metering devices totaling 25 pounds or more



Optional polyethylene stands may be stacked two high to support the primary tank for gravity feed

Conical Bottom Storage Tanks



Our seamless polyethylene conical bottom tanks feature built-in 30-degree or 45-degree slopes and built-in gallon markers and access openings. You can choose from virgin high-density cross-linked polyethylene or FDA-compliant linear polyethylene—both more resistant to corrosion and chemicals than fiberglass, stainless steel, or mild steel.

- **Wall thickness conforms to ASTM D-1998 standards**
- **Excellent low-temperature impact resistance** and stabilized against UV-ray degradation
- **Available in a variety of colors** with optional support brackets, ladders, tie-down assemblies, and accessories

SMALL CONICAL BOTTOM STORAGE TANKS

Our smaller conical bottom storage tanks are designed to rest on plastic stands that raise them off of the floor for easy drainage. Since all of the components are plastic, the risk of corrosion is virtually eliminated.



Model Number	Capacity (US Gallons)	Slope (Degrees)	Dimensions (Inches)		Weight (Pounds)			Stand Weight (Pounds)	Access Opening (Inches)
			Diameter	Height	Linear and Crosslink Polyethylene				
					1.5 Sp. G	1.9 Sp. G	2.2 Sp. G		
ICB 60	60	45	35	46	29	29	29	77	16
ICB 100	100	45	35	56	35	35	35	77	16
ICB 200	200	45	35	80	50	50	50	77	16
ICB 250	250	45	48	72	66	66	66	210	16
ICB 350	350	45	48	85	77	77	89	210	16
ICB 500	500	45	48	105	99	125	146	260	16
OTCB 300	300	45	49	88	N/A	115	133	210	Open Top
OTCB 600	600	45	57	105	N/A	180	208	260	Open Top
OTCB 1100	1100	45	69	109	173	218	255	350	Open Top
APCB 560	560	30	54	90	N/A	180	N/A	215	16
ICB 1100	1100	45	69	116	173	218	255	350	16
ICB 1575	1575	45	86	121	325	450	521	440	16
ICB 2200	2200	30	96	119	500	600	695	440	24 Top hinged
ICB 2600	2600	45	86	159	540	700	811	440	16
ICB 3000	3000	30	90	154	620	825	955	450	16
ICB 4200	4200	30	96	177	850	1000	1158	550	16
ICB 6000	6000	30	143	162	1800	1900	2200	3200	24 Top hinged
ICB 8000	8000	30	143	190	2000	2600	3000	3200	24 Top hinged

*All 24" manway access covers are hinged. Model number availability and individual specifications subject to change without notice. Gallonage and weights are approximate.

Cylindrical Horizontal Tanks



Just like our vertical storage tanks, Assmann cylindrical horizontal tanks (IHT, AHT) are molded with your choice of virgin high-density cross-linked polyethylene or FDA-compliant linear polyethylene. Both are more corrosion- and chemical-resistant than fiberglass, stainless steel, and mild steel.

- **Semi-translucent and seamless**, with gallon markers and access openings built in
- **Narrow tank diameters** save space in your plant
- **Choose from a variety of sizes**, configurations, colors, and accessories to fit your needs
- **Horizontal stands include** epoxy primer and top coat

Model Number	Capacity (US Gallons)	Dimensions (Inches)		Weight (Pounds) Liner and Crosslink Polyethylene			Stand Weight (Pounds)	Access Openings (Inches)
		Diameter	Height	1.5 Sp. Gravity	1.9 Sp. Gravity	2.2 Sp. Gravity		
IHT 25	25	23	23	11	13	16	22	7
IHT 55	55	23	36	20	22	29	35	7
IHT 150	150	32	55	50	55	73	51	7
AHT 150	150	38	42	55	60	81	64	8
IHT 200	200	32	68	65	70	95	69	7
AHT 200	200	38	53	70	95	110	72	8
IHT 300	300	38	73	75	105	122	91	8
IHT 500	500	48	74	120	130	176	116	8
IHT 1000	1000	49	140	325	400	477	230	16
IHT 1650	1650	59	157	500	600	733	290	16
IHT 2500	2500	64	191	650	770	953	1100	21

Model number availability and individual specifications subject to change without notice. Gallonage and weights are approximate.



Free-Standing Horizontal Leg Tanks



Free-standing horizontal storage tanks (IHFS) have molded-in legs, requiring no steel cradle support.

- **Semi-translucent and seamless**, with gallon markers and access openings built-in
- **Molded-in legs** eliminate the need for steel cradles
- **Narrow tank diameters** save space in your plant
- **Choose from a variety of sizes**, configurations, colors, and accessories to fit your needs

Model Number	Capacity (US Gallons)	Dimensions (Inches)			Weight (Pounds) Linear and Crosslink Polyethylene		Access Openings (Inches)
		Diameter	Length	Height	1.5 Sp. Gravity	1.9 Sp. Gravity	
IHFS 55	55	26	33	30	30	35	7/11
IHFS 80	80	25 1/2	43 1/2	30 1/2	45	N/A	7/11
IHFS 110	110	29	46	34	60	69	7/11
IHFS 200	200	35	58	40	85	98	7/11
IHFS 300	300	41	68	45	110	127	7/11
IHFS 500	500	47	76	50	145	168	7/11

Model number availability and individual specifications subject to change without notice. Gallonage and weights are approximate.



Double Wall Base Containers



Rectangular, low profile, chemical storage tank for various material handling applications. Features a primary tank that holds 450 US gallons, allowing intermediate bulk containers (IBC) to be quickly emptied and get back on the road. Constructed from crosslink polyethylene or FDA-approved and NSF-certified linear polyethylene.

Model Number	Capacity (US Gallons)	Dimensions (Inches)			Weight (Pounds) Linear and Crosslink Polyethylene		Access Opening (Inches)
		Width	Length	Height	1.9 Sp. Gravity	2.2 Sp. Gravity	
BC 450	450	73	73	44	802	N/A	11

Model number availability and individual specifications subject to change without notice. Gallonage and weights are approximate.



Open Top Tanks

Our industrial open top (IOT) tanks are molded from your choice of virgin high-density cross-link or NSF-certified linear polyethylene. These flat-bottomed vertical tanks are molded with a stiffening lip on the top to give the tank rigidity, and they are equipped with a shoe-box style cover.

Assmann open top tank covers include a unique design that allows the lid to be hinged and stay open. They are available in a variety of colors and in sizes ranging from 30 to 680 gallons. We also offer both stainless steel and mild steel epoxy-coated agitator support stands.

Model Number	Capacity (US Gallons)	Dimensions (Inches)		Weight (Pounds) 1.9 Sp. Gravity		Access Opening (Inches)
		Diameter	Height	Linear Polyethylene	Crosslink Polyethylene	
IOT 30	30	19	30	18	18	Open top
IOT 40	40	18	41	27	27	Open top
IOT 55	55	22 3/8	37 1/2	30	30	Open top
IOT 70	70	22	46	33	33	Open top
IOT 90	90	24	50	42	42	Open top
IOT 150	150	30	51	55	55	Open top
IOT 210	210	35	52	65	65	Open top
IOT 300	300	42	57	95	95	Open top
IOT 400	400	69	32	120	120	Open top
IOT 680	680	69	48	130	130	Open top

Industrial Mini Bulk and Mini Drum Tanks



Assmann industrial mini bulk (IMB) and industrial mini drum (IMD) tanks are molded in either high-density cross-link polyethylene or NSF-certified linear polyethylene.

Molded polyethylene skids are optional for both IMB 120 and 200 models. These skids allow the tank to be lifted and relocated during non-use periods. These non-standard-size storage tanks have unique features, including molded-in baffles and forklift access.

Model Number	Capacity (US Gallons)	Dimensions (Inches)		Weight (Pounds) 1.9 Sp. Gravity		Access Opening (Inches)
		Diameter	Height	Linear Polyethylene	Crosslink Polyethylene	
IMB 120	120	40	30	40	40	6
IMB 200	200	40	44	50	50	6
IMD 110	110	37	32	35	35	6
IMD 175	175	37	45	50	50	6



OUR TANKS
 MAKE IT EASY
 TO KEEP
 OUR WORD.

Rectangular Secondary Containment Basins



Assmann rectangular secondary containment basins (IRD) are molded-in virgin high-density cross-linked or FDA-compliant linear polyethylene and meet or exceed EPA requirements for containment of dangerous chemicals.

Our basins feature a tapered design for nesting during shipping. When determining the size of secondary containment basins, always refer to factory drawings to confirm primary storage tank size compatibility.

Model Number	Capacity (US Gallons)	Dimensions (Inches)			Contains Tank Max. Diameter (Inches)	Access Opening (Inches)
		Length	Width	Height		
IRD 40	52	32	26	20	20	25
IRD 80	95	47	32	20	24	40
IRD 140	155	52	38	24	29	65
IRD 185	185	64	52	16	40	47
IRD 200	200	57 1/2	45	24	35	75
IRD 240	240	60	43	28	35	80
IRD 275	275	64 1/2	52	24	42	75
IRD 330	330	72	43	31	35	90
IRD 375	375	66	66	24	58	100
IRD 385	385	91	63	19	50	90
IRD 440	440	72	60	30	54	175
IRD 495	495	69	69	29	61	125
IRD 660	660	83	64	40	48	220
IRD 950	950	83	83	46	68	320
IRD 1650	1650	99	99	53	84	400
IRD 1750	1750	218	108	21	2 each 90	400
IRD 3500	3500	218	108	40	2 each 90	700

Model number availability and individual specifications subject to change without notice. Gallonage and weights are approximate.

Cylindrical Secondary Containment Basins



Our cylindrical secondary containment basins (IRD) are available in either virgin high-density cross-linked or FDA-compliant linear polyethylene and meet or exceed EPA standards for containment of dangerous chemicals.

A 2" x 2" x 3/16" angle iron top support ring is optional and can be ordered separately. Epoxy-painted mild steel or 316 stainless steel rings are also available.

Model Number	Capacity (US Gallons)	Dimensions (Inches)		Contains Tank Max. Diameter (Inches)
		Diameter	Cut Height	
IRD 550	up to 690	60	0 to 58	48
IRD 1050	up to 1200	72	58 to 72	64
IRD 1550	1200 - 1800	72	72 to 108	64
IRD 2300	1800 - 2300	72	108 to 135	64
IRD 1100	up to 982	86	0 to 40	82
IRD 1500A	982 to 1301	86	40 to 53	82
IRD 2000	1301 to 1891	86	53 to 77	82
IRD 2500	1891 to 2406	86	77 to 98	82
IRD 3000	up to 2881	90	0 to 107	86
IRD 4000	2881 to 3877	90	107 to 144	86
IRD 1850	up to 1760	96	0 to 58	92
IRD 2400	1760 to 2277	96	58 to 75	92
IRD 2900	2277 to 2762	96	75 to 91	92
IRD 4100	up to 3900	119	0 to 84	115
IRD 4200	2762 to 4200	96	91 to 140	92
IRD 5600	4200 to 5300	96	140 to 177	92
IRD 5200	up to 4800	105	0 to 133	101
IRD 6500	4800 to 6200	105	133 to 172	101
IRD 5500	3900 to 5400	119	84 to 116	115
IRD 6510	5400 to 6100	119	116 to 131	115
IRD 8000	up to 7800	143	0 to 116	139
IRD 10000	7800 to 9900	143	116 to 147	139
IRD 12000	9900 to 11000	143	147 to 163	139

Model number availability and individual specifications subject to change without notice. Gallonage and weights are approximate. All wall thicknesses conform to ASTM D-1998.

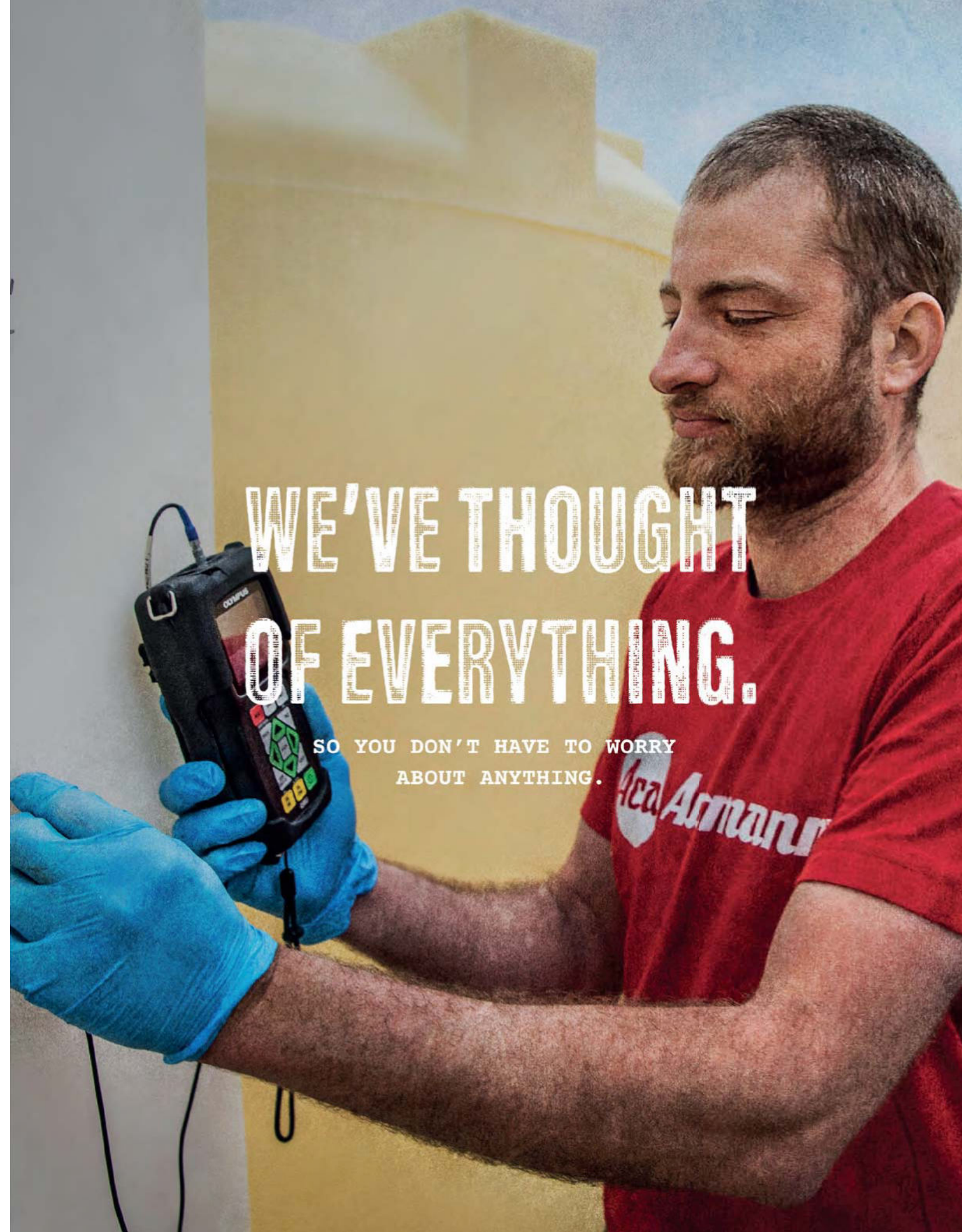

WE'VE THOUGHT
OF EVERYTHING.

SO YOU DON'T HAVE TO WORRY
ABOUT ANYTHING.

Acqua Ammanu

Accessories

Assmann offers a wide variety of accessories to complement our storage tank line. These accessories vary in material type. The table on this page identifies the material options available for the accessories on the upcoming pages.

LEGEND

Abbreviation	Material	Abbreviation	Material	Abbreviation	Material
PVC	Polyvinyl Chloride	PVDF	Polyvinylidene Fluoride	Has	Hastelloy
P/P	Polypropylene	Tit	Titanium	VITON®	DuPont Fluoroelastomer
316 SS	Type 316 Stainless Steel	Virgin P/P	Unpigmented Virgin Polypropylene	XLPE	Cross-linked Polyethylene
CPVC	Chlorinated Polyvinyl Chloride	EPDM	Ethylene Propylene Diene Copolymer	BUNA-N	Butadiene Elastomer

Accessory	Fitting Material	Encapsulated Bolt Bolt/Capsule	Flange Gasket	Flange Adapter	Siphon Drain
Flange Fittings	PVC	SS/EPDM	EPDM	PVC	PVC
	P/P	SS/VITON	VITON	P/P	P/P
	316 SS	Titanium/EPDM	XLPE	316 SS	316 SS
	CPVC	Titanium/VITON	BUNA-N	CPVC	CPVC
	PVDF	Has/VITON		PVDF	PVDF
	Virgin P/P			Virgin P/P	Virgin P/P

Accessory	Fitting Material	Flange Gasket	Flange Adapter	Siphon Drain
Bulkhead Fittings	PVC	EPDM	PVC	PVC
	P/P	VITON	P/P	P/P
	CPVC	XLPE	CPVC	CPVC
	PVDF	BUNA-N	PVDF	PVDF
	Virgin P/P		Virgin P/P	Virgin P/P

Accessory	Type	Gasket	Flange Adapter	Siphon Drain
Hastelloy	Male - Double Male	EPDM VITON XLPE BUNA-N	PVC P/P CPVC PVDF Virgin P/P	PVC P/P CPVC PVDF Virgin P/P
Stainless Fittings	Male			
	Female			
	Double Male			
Titanium	Male - Double Male			

Accessory	Fitting Material	Flange Gasket	Flange Adapter
Self-Aligning Dome Fittings	PVC CPVC	EPDM VITON XLPE BUNA-N	PVC CPVC P/P

Accessory	U-Vent Material	Gasket	Screen
U-Vent Assemblies	PVC Sch 40 PVC Sch 80 P/P Sch 80 CPVC Sch 80	EPDM VITON XLPE BUNA-N	Stainless Steel

Accessory	Fill Line Material	Drop Tube Material	Bracket Bolts Bolt/Capsule	Bracket Gasket	Union
Fill Line/ Drop Tube Assemblies	PVC P/P	PVC P/P	SS/EPDM SS/VITON Titanium/EPDM Titanium/VITON Has/VITON	EPDM VITON XLPE BUNA-N	PVC P/P

Accessory	Type	Sight Gauge Material	Ball Valve Seals
Sight Gage Assemblies	Single Valve Double Valve Triple Valve	PVC	EPDM VITON

Accessory	Elbow Material
Anti-Foam Elbow	PVC P/P CPVC PVDF



Flange Fittings



Assmann flange fittings connect inlet or drainage plumbing through the wall of the tank. These fittings are secured by metal bolts encapsulated in EPDM or VITON elastomers which provide compression for a positive seal.

- **Order by size and material**
- **Bolts, gasket, and flange** must be ordered separately
- **ANSI-150 psi flange adapter** consists of a nipple and flange and converts a threaded connection to a mating flange. Length of the adapter can be made to your specifications
- **Siphon drain** consists of welded nipple, 90-degree elbow and nipple to extend to 1/2" above tank floor

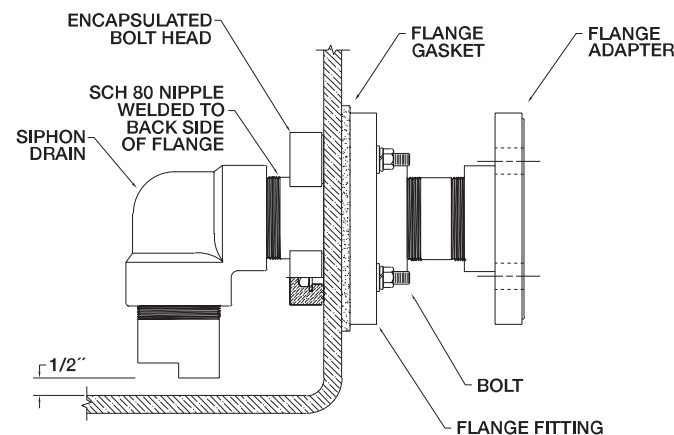

Flange Fittings Available Sizes (Inches)

Size	1/2	3/4	1	1 1/4	1 1/2	2	2 1/2	3	4	6	8
Bolts	4	4	4	4	4	4	4	4	8	8	8

Bulkhead Fittings



Bulkhead fittings are an economical choice for tank-to-plumbing connections. These fittings are available in a variety of materials.

- **Bulkhead fittings and gaskets** must be ordered separately
- **Assmann's ANSI-150 psi flange adapter** consists of a nipple and flange and converts a threaded connection to a mating flange
- **Siphon drains** are threaded to fit to bulkhead fittings

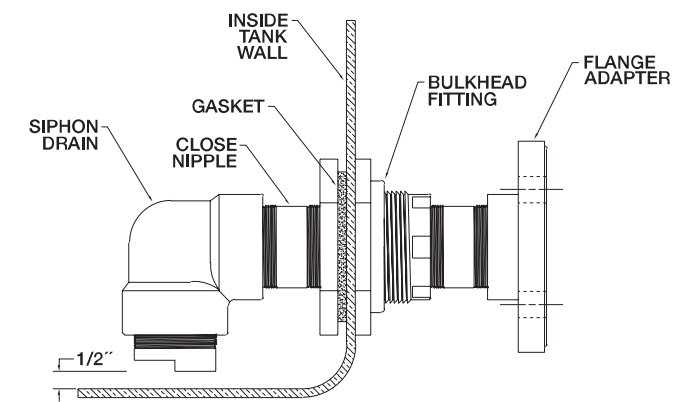

Bulkhead Fittings Available Sizes (Inches)

Size	1/2	3/4	1	1 1/4	1 1/2	2	3	4



316 Stainless Steel Fittings



These fittings provide a through-tank wall connection for applications with stringent sanitary requirements met by Type 316 stainless steel. All components except the gasket are made of 316 stainless steel.

THERE ARE THREE TYPES IN NINE SIZES:

- **Male fitting:** Male pipe thread outside tank wall only
- **Female fitting:** Female pipe thread inside and outside of tank wall
- **Double male fitting:** Male pipe thread inside and outside of tank wall

The flange adapter and siphon drain (if applicable) can be applied to all three stainless fitting types listed above.

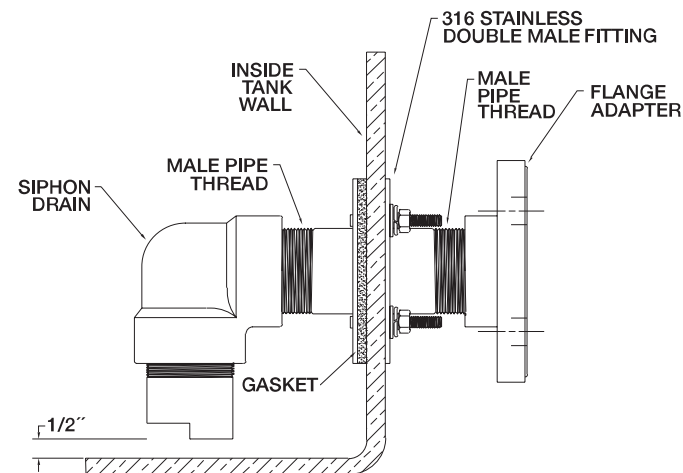

316 Stainless Steel Fittings Available Sizes (Inches)

Size	1/2	3/4	1	1 1/4	1 1/2	2	2 1/2	3	4
Bolts	4	4	4	4	4	4	4	8	8

These fittings are also available in hastelloy and titanium construction, male and double male only.

PVC Self-Aligning Dome Fittings



Assmann PVC self-aligning dome fittings provide a vertical plumbing connection at the top of tanks with a radius dome. Three sizes of PVC fittings are available.

- **The ball socket design** corrects for the slope of the dome
- **The fittings have female pipe thread** inside and outside of tank wall
- **Fitting and gasket** must be ordered separately

Self-Aligning Dome Fittings Available Sizes (Inches)

Size	1	2	3
Bolts	4	4	4

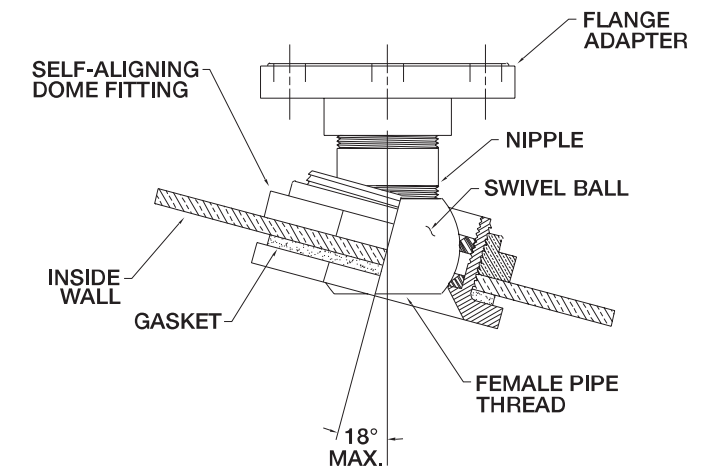

Polyethylene Welded Connections for Linear Tanks



FDA-compliant welded polyethylene fittings are designed for use in food, cosmetic, and pharmaceutical industries. Certified welders provide a variety of custom-welded accessories. Polyethylene welded fittings and some welded accessories may only be welded to 1.9 specific gravity or higher tanks.

Polyethylene Full Female Couplers

Available Sizes (Inches)

Size	3/4	1	1 1/2	2	3

Polyethylene Flange Connections

Available Sizes (Inches)

Size	1	2	3	4	6	8	10	12

Polyethylene Pipe Support Brackets

Available Sizes (Inches)

Size	1-3	4-6	6-12

Polyethylene Sch 80 Pipe Per Foot

Available Sizes (Inches)

Size	1	2	3	4	6	8	10	12

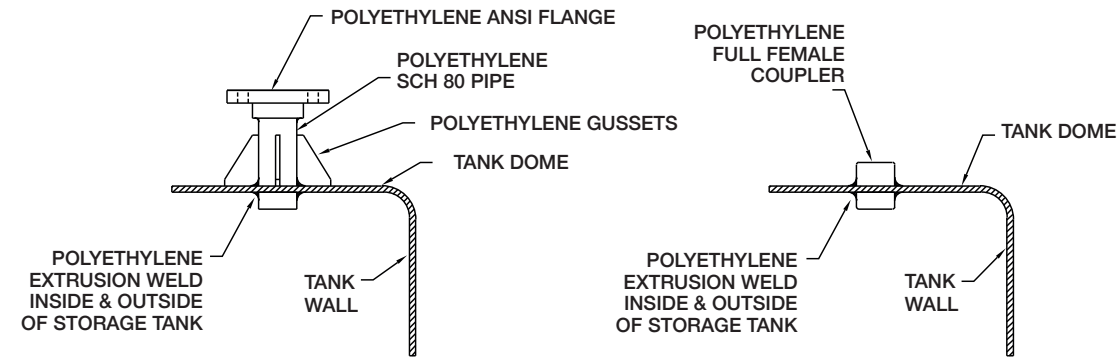

Vent Assemblies

Assmann vent assemblies are available in sizes from 2" to 6". Vent gasket and bolts (where applicable) must be ordered separately. Polyethylene or stainless steel screens are optional and must be ordered separately.

Vent Assembly Sizes (Inches)

Size	2	3	4	6

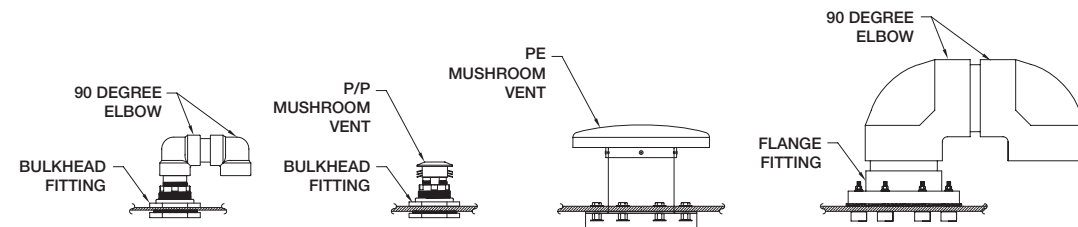

Fill Line / Suction Line Assemblies



Our fill line and suction line assemblies make it possible to fill your tank from a convenient position outside the tank.

THE FILL LINE INCLUDES:

- Exterior drop tube
- 90-degree elbow
- Ball valve
- Male quick disconnect coupling
- Dust cap
- Exterior pipe support bracket

THE INTERIOR SUCTION LINE ASSEMBLY INCLUDES:

- Interior drop tube
- Pipe support bracket
- Optional foot valve with screen

Gasket and bolts must be ordered separately. Optional union may be ordered with exterior fill line. Optional foot valve may be ordered with internal suction line. Fill line and suction line assemblies do not include through-wall fittings.

Fill Line / Anti-Foam Elbows

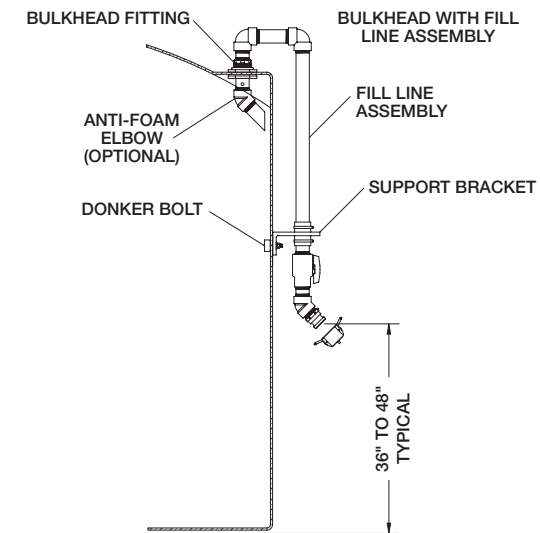

Top Suction

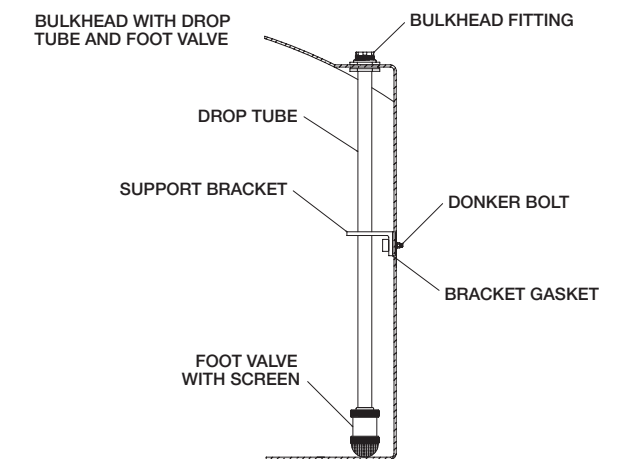

Anti-Foam Elbow

This assembly with 45-degree elbow and nipple extends to within 3" of the tank wall and directs liquid to run smoothly down the interior surface of the tank. This will reduce the generation of foam on the surface of the contents. Through-wall fitting is not included and must be ordered separately.

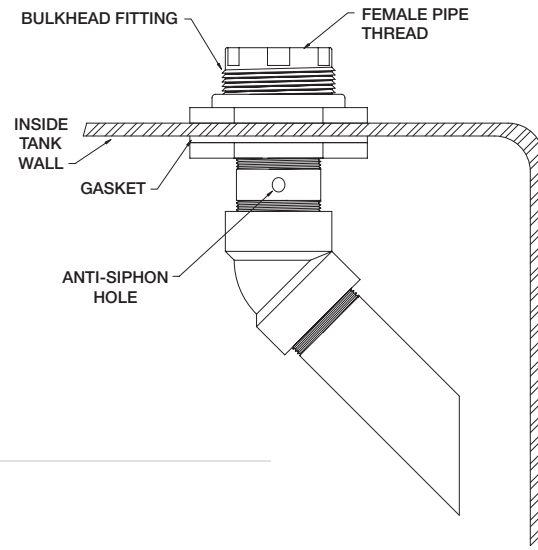

Anti-Foam Elbow Available Sizes (Inches)

Size	1	2	3	4

Sight Gauge Assemblies

Assmann sight gauge assemblies of 3/4" PVC tubing and fittings are available in single-, double-, and triple-valve configurations.

ASSEMBLY INCLUDES:

- Ball valve(s)
- Nipples
- 90-degree elbows

- Stainless steel hose clamps
- Hose barbs
- Clear flexible PVC
- Threaded T-fitting where applicable

Through-wall fittings and/or bulkhead fittings are not included and must be ordered separately.

Single Valve Sight Gauge

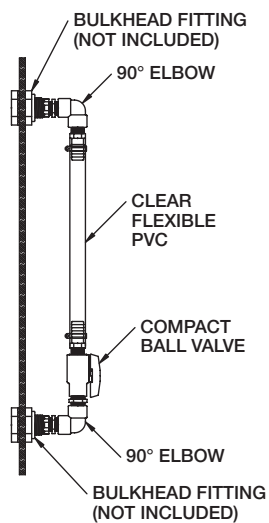

Double Valve Sight Gauge

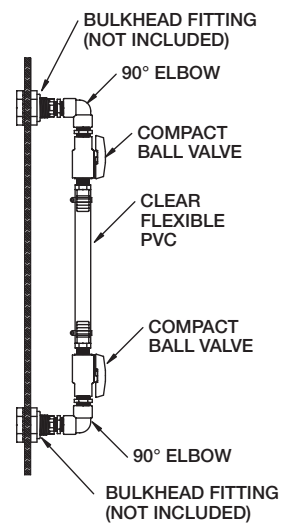

Triple Valve Sight Gauge

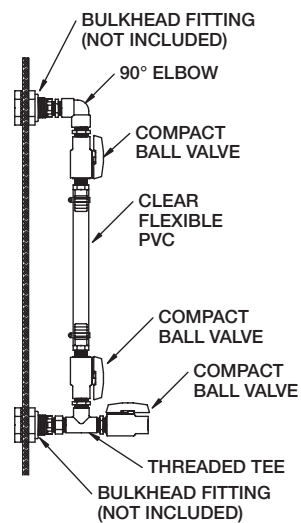

Reverse Float Level Indicator

Our reverse float level indicator is an excellent way to eliminate sidewall penetrations on your polyethylene tank.

This system shows liquid level in your storage tank by utilizing a molded polyethylene float that rides on the liquid within. A bright orange target shows the liquid level in reverse action: as the liquid in the tank drops, the bright orange target rises, so you can have an approximate read on the level in the tank.

This gauge is ideal for use on colored tanks, insulated tanks, or double wall tanks when you cannot see the liquid level through the tank wall.



Leak Detection System

Our leak detectors are designed with a NEMA 4X enclosure, which makes them suitable for both indoor and outdoor double wall tank applications. The control box is built from sturdy FRP construction with stainless steel lid hinge and clasp.

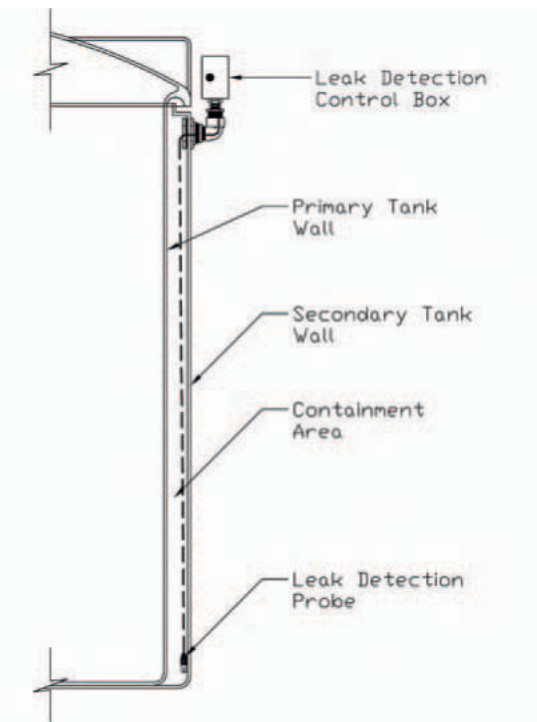

Restraint Tie-Down and Lifting Lugs System



Our unique molded polyethylene restraint and lifting lugs system is the first ever polyethylene restraint system that combines both a restraint and a lifting system all in one package. Site-specific calculations prove that both the tank and system are designed to meet the site criteria. This system is the most economical engineered system on the market today.

- **Engineered for long-term exposure** in corrosive environments
- **Easily installed with factory cabling**, this system has been certified on applications with 150 MPH sustained wind loads
- **Reduced over-turning moment** due to the unique bump stop that encompasses the tank's knuckle radius
- **Easy empty tank placement and removal** thanks to the mechanically fastened lifting lugs. Cable types available are either galvanized or 316 stainless steel.
- **Zoning:** Assmann also offers restraint systems that can be installed in the field. These systems were certified to UBC1997 standards for Seismic Zone 4 and 120 MPH wind loads. While these standards are outdated, this system can still be used and possibly certified when "in the field" installations are required.

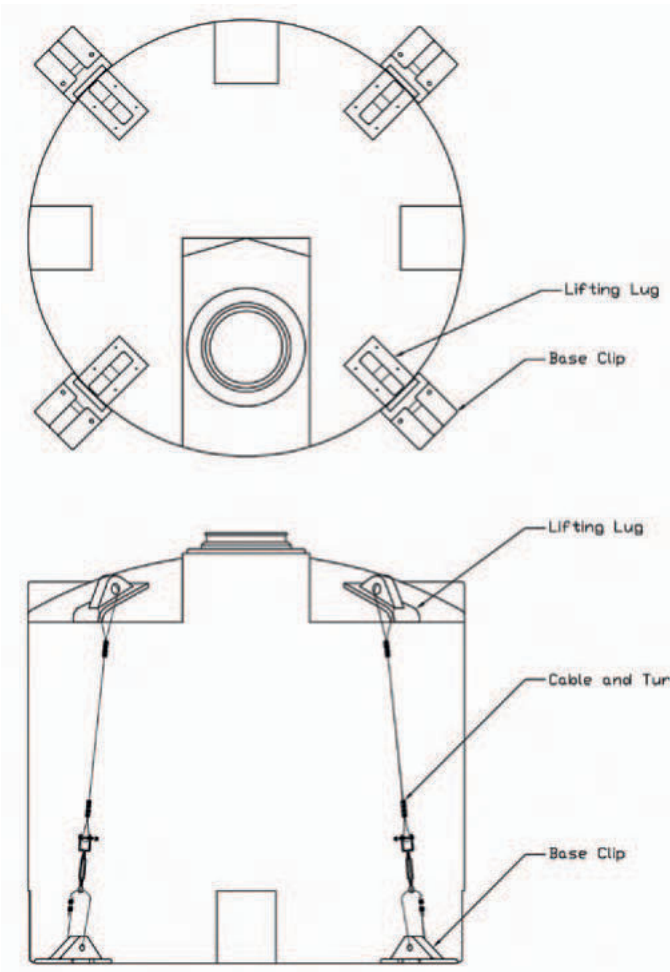

Tank Heat Tracing and Insulation



Assmann tanks are available with a heating system to maintain the level required by temperature-sensitive stored liquids. We wrap the tank with water-resistant, adhesive-backed heat tracing elements and cover them with a two-inch thick layer of polyurethane foam insulation and two coats of mastic.

A control panel regulates temperature measured by high-level and maintenance-level thermostats set to desired limits. Using different heat tracing elements, temperature can be maintained at any point above 50°F, 80°F, or 100°F over the lowest ambient temperature to which the tank is subjected.

AVAILABLE FOR:

- Vertical tanks from 300 to 12,000 gallons capacity
- Conical bottom tanks from 1,575 to 4,200 gallons
- Horizontal cylindrical tanks from 500 to 2,500 gallons

When requesting information, specify the gallon capacity and the Delta T (DT) for your material. The temperature differential is calculated by subtracting the minimum ambient temperature to which the tank is subject from the temperature at which your material must be maintained.

Control box (115V dual thermostats, 1 high level, 1 maintenance level).

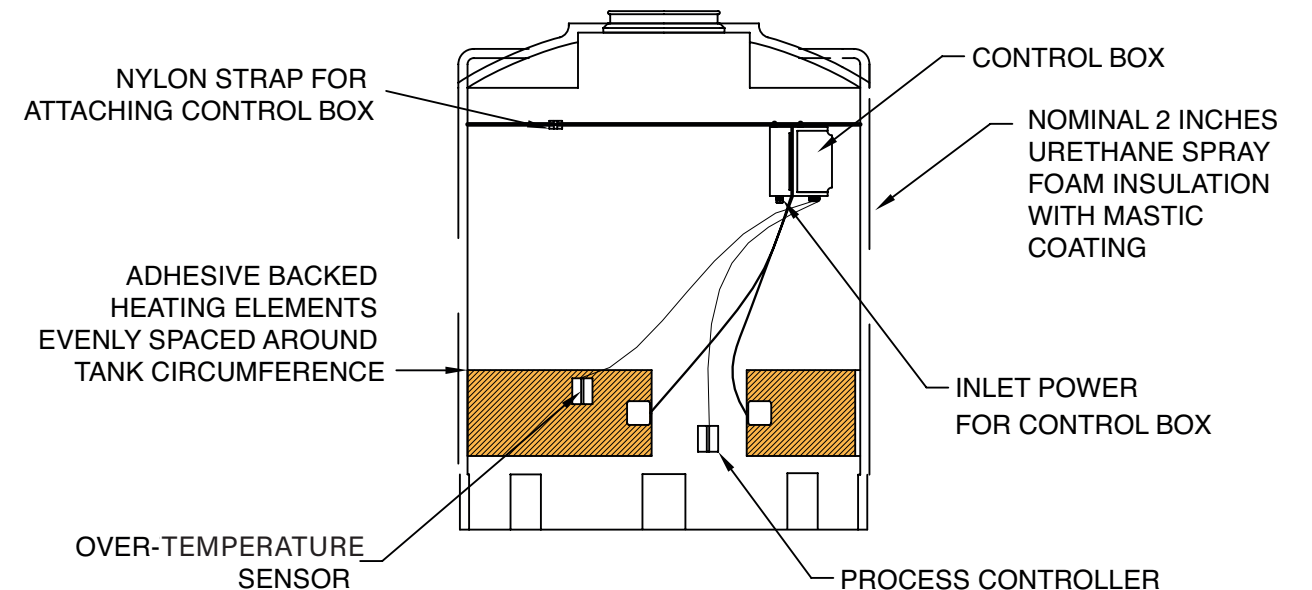



Fiber-Reinforced Ladder Assemblies

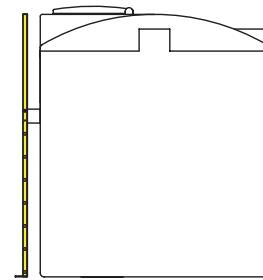

Assmann fiber-reinforced ladders conform to OSHA requirements and allow you to easily access tank lids and accessories.

LADDER ASSEMBLIES ARE AVAILABLE IN FOUR CONFIGURATIONS:

- Ladder
- Ladder with platform
- Ladder with cage
- Ladder with cage and platform

These ladders are not designed to gain entry into the interior of tanks or for access to dome.

FRP Ladder with Platform

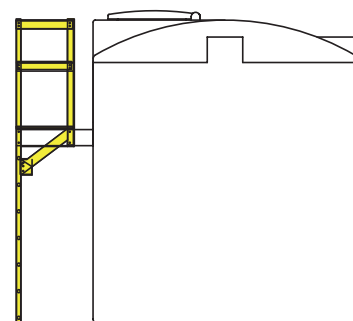

FRP Ladder with Cage

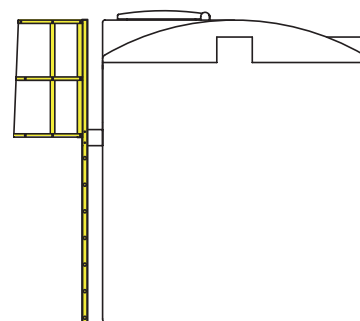

FRP Ladder with Cage & Platform

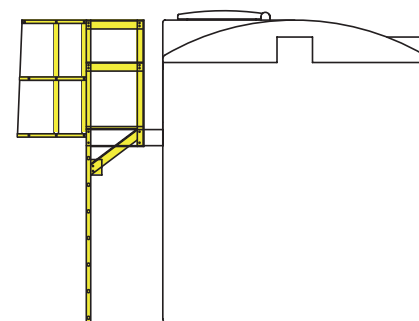

Agitator Support Brackets for Vertical and Conical Tanks

Our self-supporting agitator support brackets are designed to handle mixers with horsepower ratings of 3 or 5 HP. Agitator support stands are made from mild steel and are epoxy painted as a standard. 304 stainless steel is optional.

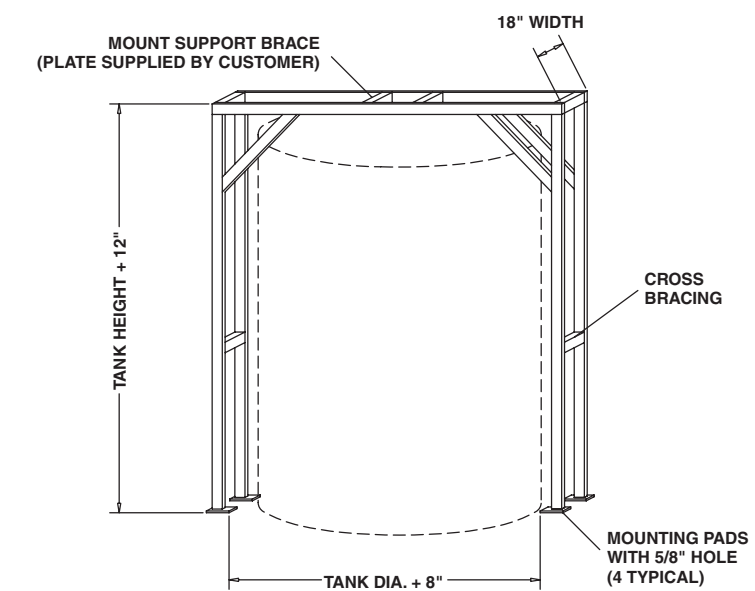

CUSTOMER TO PROVIDE MIXER MOUNTING HOLES/BOLTS OR PLATE ONSITE
 3HP WITH 18" MOUNTING SUPPORT SPACING 2" x 2" x 3/16" TUBE 4" x 6" x 1/4" MOUNTING PADS
 5HP WITH 24" MOUNTING SUPPORT SPACING 3" x 3" x 3/16" TUBE 4" x 8" x 1/4" MOUNTING PADS

Your Pre-Quote Checklist

HELP US GIVE YOU THE BEST QUOTE

The more details you can share, the better our recommendations. Use this checklist to gather all of your important information in one place, and then contact your Assmann team.

Chemical or fluid to be stored	
Volume/gallons to be stored	
Type of polyethylene for intended application	
Address of installation location	

Estimated completion date desired	
Number of tanks, model, dimensions, color anticipated	
Fittings, size, material desired	
Space limitations, ambient environment characteristics	
Temperature maintenance requirements	
Other information you need to share	

Assmann Product Ratings and Temperature Performance

This information is based on our experience, research, and support from other published chemical resistance charts. It is believed to be reliable; it is, however, intended to be used only as a guide. Assmann Corporation of America assumes no responsibility in connection with its use.

Additional assistance should be requested if there are doubts about compatibility, sustainability, warranty, allowable transportability, or storage in Assmann products.

SERVICE TEMPERATURE LIMITATIONS

Cross-linked polyethylene: -40° F to +150° F

Linear polyethylene: -20° F to +120° F

Note: Constant service temperatures above 100° F greatly reduce useful tank life, please consult factory.

Ratings	Chemical Attack		
A	No Effect	Excellent	At ambient temperature
B	Minor Effect	Good	At ambient temperature
C	Moderate Effect	Fair	Additional research required
D	Severe Effect	NOT RECOMMENDED	
-	No Data		

Chemical Name	Polyethylene	Polypropylene	PVC	316 Stainless Steel	Titanium	Hastelloy C-276	Viton	EPDM
Acetic Acid* 1-10%	A	A	B	A	B	A	C	A
Acetic Acid* 10-60%	A	A	C	A	B	A	C	A
Acetic Acid* 80-100%	A	A	C	A	B	A	C	B
Aluminum Chloride-dilute	A	A	A	C	A	A	A	A
Aluminum Chloride-conc.	A	-	A	C	A	A	A	A
Aluminum Fluoride-conc.	A	A	A	C	A	B	-	A
Aluminum Sulfate-conc	A	A	A	A*	A	A	A	A
Alums (all types) conc***	A	A	A	A	A	A	A	A
Ammonia 100% Dry Gas	A	A	A	A	A	-	-	B
Ammonium Carbonate	A	A	A	A	A	B	B	C
Ammonium Chloride-sat'd	A	A	A	A	-	A	B	A
Ammonium Fluoride 20%	A	-	A	-	-	-	-	-
Ammonium Hydroxide 0,888 sq	A	A	A	A	A	A	B	A
Ammonium Metaphosphate sat'd	A	A	A	-	-	-	-	-
Ammonium Nitrate sat'd	A	A	A	A	A	A	B	A
Ammonium Persulfate sat'd	A	A	A	A	-	A	A	B

Chemical Name	Polyethylene	Polypropylene	PVC	316 Stainless Steel	Titanium	Hastelloy C-276	Viton	EPDM
Ammonium Sulfate sat'd	A	A	A	A	A	B	-	A
Ammonium Sulfide sat'd	A	-	-	A	A	B	D	A
Ammonium Thiocyanate sat'd	A	-	-	-	-	-	-	-
Amyl Alcohol* 100%	A	A	A	A	-	A	B	A
Aniline 100%	A	B	A	A	C	B	D	A
Antimony Chloride	A	-	-	-	-	-	-	A
Barium Carbonate sat'd	A	A	A	A	A	-	-	A
Barium Chloride	A	A	A	A	A	A	B	-
Barium Hydroxide	A	A	A	A	B	B	A	A
Barium Sulfate sat'd	A	A	A	A	-	-	A	A
Barium Sulfide sat'd	A	A	A	A	-	-	A	A
Benzene Sulfonic Acid*	A	D	-	-	-	-	-	A
Borax Cold sat'd	A	A	A	A	A	A	A	A
Boric Acid Dilute	A	A	A	A	A	A	A	A
Boric Acid Conc	A	A	A	A	-	A	A	A
Bromic Acid 10%	A	D	-	-	-	-	-	-

Chemical Name	Polyethylene	Polypropylene	PVC	316 Stainless Steel	Titanium	Hastelloy C-276	Viton	EPDM
Calcium Bisulfide	A	A	A	B	A	A	A	-
Calcium Carbonate sat'd	A	A	A	A	A	A	A	A
Calcium Chlorate sat'd	A	A	A	-	A	-	-	A
Calcium Chloride sat'd	A	A	A	A	A	A	A	A
Calcium Hydroxide	A	A	A	A	A	A	A	A
Calcium Hypochlorite Bleach	A	A	A	B	A	A	A	A
Calcium Nitrate 50%	A	-	A	-	-	-	-	A
Calcium Sulfate	A	A	A	A	-	B	A	A
Carbon Dioxide 100% Dry	A	A	A	A	A	-	B	A
Carbon Dioxide 100% Wet	A	A	A	A	A	-	B	A
Carbon Dioxide Cold sat'd	A	-	A	A	A	-	B	A
Carbonic Acid	A	-	A	B	-	A	A	A
Castor Oil* Conc	A	-	A	-	-	A	A	A
Chrome Alum sat'd	A	-	B	-	-	-	A	B
Chromic Acid 20%	A	A	B	A	A	A	A	D
Cider*	A	-	A	A	-	-	A	-
Citric Acid* sat'd	A	B	A	A	A	A	A	A
Coconut Oil Alcohols*	A	-	-	A	-	-	A	D
Cola Concentrates*	A	-	-	A	-	-	-	-
Copper Chloride sat'd	A	A	A	D	A	-	A	A
Copper Cyanide sat'd	A	A	A	A	-	A	A	A
Copper Flouride 2%	A	-	A	D	-	-	-	-
Copper Nitrate sat'd	A	A	A	A	A	A	A	-
Copper Sulfate Dilute 5%	A	A	A	A	A	-	A	A
Copper Sulfate sat'd	A	-	-	A	A	-	-	A
Cottonseed Oil*	A	-	A	A	-	-	A	B
Cuprous Chloride sat'd	A	-	-	-	-	-	A	A
Cyclohexanol*	A	-	-	A	-	-	A	D
Detergents Synthetic*	A	A	A	A	-	-	A	A
Developers, Photographic	A	-	A	A	A	-	A	-
Dextrin sat'd	A	-	-	-	-	-	-	-
Dextrose sat'd	A	A	A	-	-	-	-	-
Dibutyl Phthalate	A	-	-	-	-	-	B	C
Disodium Phosphate	A	A	D	D	D	A	A	-
Ethylene Glycol*	A	D	A	A	-	-	A	A
Ferric Chloride sat'd	A	A	A	D	D	-	A	A
Ferric Nitrate sat'd	A	A	A	A	-	-	A	A
Ferric Sulfate	A	A	A	A	A	A	A	A
Ferrous Chloride sat'd	A	A	A	D	A	-	A	A
Ferrous Sulphate	A	A	A	A	A	B	A	A
Fluoboric Acid	A	-	A	B	D	A	A	D
Fluosilicic Acid 32%	A	-	A	C	-	B	A	A

Chemical Name	Polyethylene	Polypropylene	PVC	316 Stainless Steel	Titanium	Hastelloy C-276	Viton	EPDM
Fluosilicic Acid conc.	A	-	A	D	-	B	A	A
Formaldehyde* 40%	A	A	A	A	A	A	A	A
Formic Acid* 0-20%	A	A	D	A	-	A	B	A
Formic Acid* 20-50%	A	A	D	A	C	A	B	A
Formic Acid* 100%	A	A	D	A	-	A	B	A
Fructose sat'd	A	A	A	A	-	-	-	-
Fruit pulp	A	A	A	A	-	-	A	-
Gallic Acid sat'd	A	-	-	-	-	-	-	A
Glucose	A	A	A	A	-	-	A	A
Glycerine*	A	A	A	A	A	A	A	A
Glycol*	A	-	A	-	-	-	-	A
Glycolic Acid* 30%	A	A	A	-	-	A	A	-
Grape Sugar sat'd ag	A	A	A	A	-	-	-	-
Hydrobromic Acid 50%	A	B	A	D	A	A	A	-
Hydrocyanic Acid sat'd	A	A	A	-	C	A	A	-
Hydrochloric Acid 10%	A	A	A	D	C	A	A	A
Hydrochloric Acid 30%	A	A	A	D	C	A	A	A
Hydrochloric Acid 35%	A	A	A	D	C	A	A	D
Hydrochloric Acid conc.	A	A	A	D	C	A	A	D
Hydrofluoric Acid 40%	A	A	D	D	D	B	A	D
Hydrofluoric Acid 60%	A	D	D	D	D	B	A	D
Hydrofluoric Acid 75%	A	D	D	D	D	B	A	D
Hydrofluosilicic Acid	A	B	B	B	D	A	-	A
Hydrogen Bromide 10%	A	-	D	-	-	-	-	-
Hydrogen Peroxide 30%	A	A	A	A	B	A	A	D
Hydrogen Peroxide 90%	A	A	A	D	B	A	A	D
Hydrogen Phosphide 100%	A	-	-	-	-	A	-	-
Hydroquinone	A	-	-	-	-	-	-	C
Hydrogen Sulfide	A	A	A	A	A	-	D	B
Inks*	A	-	-	A	-	-	A	-
Iodine (alc. Sol) conc.	A	D	D	D	A	B	A	B
Lactic Acid* 10%	A	A	A	-	A	-	A	A
Lactic Acid* 90%	A	A	A	A	A	-	A	B
Latex*	A	A	A	A	-	-	A	A
Lead Acetate sat'd	A	A	A	B	A	-	D	A
Lube Oil	A	A	A	A	-	-	A	C
Magnesium Carbonate sat'd	A	A	A	A	-	B	-	-
Magnesium Chloride sat'd	A	A	A	A	A	A	A	A
Magnesium Hydroxide sat'd	A	A	A	A	A	-	A	A
Magnesium Nitrate sat'd	A	A	A	A	-	-	-	A
Magnesium Sulphate sat'd	A	A	A	A	A	B	A	A
Mercuric Chloride sat'd	A	-	A	D	A	B	A	A

Chemical Name	Polyethylene	Polypropylene	PVC	316 Stainless Steel	Titanium	Hastelloy C-276	Viton	EPDM
Mercurous Nitrate sat'd	A	-	A	-	-	-	-	A
Milk	A	A	A	A	A	-	A	A
Mineral Oils	A	-	A	A	-	-	-	D
Molasses	A	A	A	A	-	-	A	A
Nickel Chloride sat'd	A	A	A	A	A	-	A	A
Nickel Nitrate conc.	A	A	A	A	-	-	-	-
Nickel Sulfate sat'd	A	A	A	A	-	-	A	A
Nitric Acid* 0-30%	A	A	A	A	A	A	A	A
Oils & Fats	A	A	-	A	-	-	A	B
Oleic Acid conc.	A	A	A	A	-	-	B	D
Orange Extract*	A	-	-	A	-	-	-	-
Oxalic Acid* dilute	A	A	A	-	C	B	A	-
Oxalic Acid* sat'd	A	A	A	A	C	-	A	A
Perchloric Acid 10%	A	-	-	-	-	-	-	A
Phosphoric Acid up to 30%	A	A	A	A	A	A	A	A
Phosphoric Acid over 30%	A	A	A	B	B	A	A	A
Phosphoric Acid over 90%	A	A	A	B	B	A	A	A
Phosphoric (Yellow) 100%	A	-	-	-	-	-	-	-
Phosphorus Pentoxide 100%	A	-	-	-	-	-	-	-
Photographic Solutions	A	A	A	A	A	A	-	-
Pickling Baths								
Sulfuric Acid*	A	-	-	B	-	-	A	D
Hydrochloric Acid*	A	-	A	D	A	-	A	D
Sulfuric-Nitric*	A	-	-	B	-	-	A	D
Plating Solutions								
Brass*	A	A	A	A	-	A	-	B
Cadmium*	A	A	A	-	-	A	-	B
Copper*	A	A	A	-	-	-	A	B
Gold*	A	A	A	A	-	-	A	B
Indium*	A	A	A	A	-	-	A	B
Lead*	A	A	A	-	-	-	A	B
Nickel*	A	A	A	-	-	-	A	B
Rhodium*	A	-	-	-	-	-	-	B
Silver*	A	A	A	A	-	-	A	B
Tin*	A	A	A	A	-	-	A	B
Zinc*	A	A	A	A	A	-	A	B
Potassium Bicarbonate sat'd	A	-	A	B	-	-	A	A
Potassium Borate 1%	A	-	-	-	-	-	-	-
Potassium Bromate 10%	A	-	A	A	-	-	-	-
Potassium Bromide sat'd	A	A	A	A	A	A	-	A
Potassium Carbonate	A	A	A	A	-	B	A	A
Potassium Chlorate sat'd	A	A	A	A	-	B	A	A

Chemical Name	Polyethylene	Polypropylene	PVC	316 Stainless Steel	Titanium	Hastelloy C-276	Viton	EPDM
Potassium Chloride sat'd	A	A	A	A	A	B	A	A
Potassium Chromate 40%	A	A	A	B	A	A	A	-
Potassium Dichromate 40%	A	A	A	A	A	B	A	A
Potassium Hydroxide 20%	A	A	A	A	C	B	D	A
Potassium Hydroxide conc.	A	A	A	A	C	B	D	A
Potassium Nitrate sat'd	A	-	A	A	-	B	-	A
Potassium Perborate sat'd	A	-	-	-	-	-	A	-
Potassium Perchlorate 10%	A	-	-	-	-	-	-	-
Potassium Permanganate	A	A	D	A	A	A	A	A
Potassium Sulfate conc.	A	A	A	B	A	B	A	A
Potassium Sulfide conc.	A	A	-	-	A	-	A	B
Potassium Sulfite conc.	A	A	A	-	A	-	A	D
Potassium Persulphate sat'd	A	-	A	-	-	-	-	-
Propylene Glycol*	A	-	-	A	-	-	A	A
Rayon Coagulation Bath*	A	-	-	-	-	-	-	-
Sea Water	A	A	A	A	A	-	A	A
Selenic Acid	A	-	-	-	-	-	-	-
Shortening*	A	A	-	A	-	-	-	-
Silicic Acid	A	-	-	-	-	-	-	-
Silver Nitrate Sol.	A	A	A	A	-	-	A	A
Soap Solution* any conc	A	A	D	A	-	-	A	A
Sodium Acetate sat'd	A	A	A	A	A	-	A	A
Sodium Benzoate 35%	A	-	-	-	-	-	-	-
Sodium Bicarbonate sat'd	A	A	A	A	-	B	A	A
Sodium Bisulfate sat'd	A	A	A	A	A	A	A	A
Sodium Bisulfite sat'd	A	A	A	A	A	B	A	A
Sodium Borate	A	-	-	-	-	-	A	A
Sodium Bromide Dilute Sol.	A	-	-	-	-	-	A	-
Sodium Carbonate conc.	A	A	A	A	A	-	A	-
Sodium Carbonate	A	A	A	A	A	-	A	A
Sodium Chlorate sat'd	A	A	A	A	A	A	A	-
Sodium Chloride sat'd	A	A	A	A	A	A	A	-
Sodium Dichromate sat'd	A	-	-	-	-	-	A	-
Sodium Hydroxide conc.	A	A	A	A	A	B	B	A
Sodium Hypochlorite to 17%*	A	A	A	D	A	B	A	B
Sodium Nitrate	A	A	A	A	A	-	A	A
Sodium Sulfate	A	A	A	A	A	B	A	A
Sodium Sulfide 25%	A	A	A	A	A	-	A	A
Sodium Sulfide sat's sol	A	A	A	A	A	-	A	A
Sodium Sulfite sat'd	A	A	A	A	A	-	A	A
Stannic Chloride sat'd	A	-	A	A	A	-	A	A
Stannous Chloride sat'd sol	A	-	A	A	A	-	A	A

Chemical Name	Polyethylene	Polypropylene	PVC	316 Stainless Steel	Titanium	Hastelloy C-276	Viton	EPDM
Starch Solution* sat'd	A	-	A	-	-	-	A	A
Stearic Acid* 100%	A	D	-	-	A	-	A	C
Sulfuric Acid 0-50%	A	A	A	B	A	A	A	C
Sulfuric Acid 70%	A	A	A	B	D	B	A	D
Sulfuric Acid 80%	A	D	D	-	-	A	A	D
Sulfurous Acid	A	A	A	B	A	B	A	C
Tallow	A	-	-	A	-	-	A	A
Tannic Acid* 10%	A	A	A	A	A	-	A	A
Tanning Extracts* Comm	A	-	A	A	-	A	-	-
Tartaric Acid sat'd	A	A	A	A	A	B	A	A
Transformer Oil	A	A	A	A	-	-	A	D
Trisodium Phosphate sat'd	A	-	-	-	-	-	-	-
Urea* Up to 30%	A	-	A	A	-	-	A	-
Urine	A	A	A	A	-	-	A	-
Vinegar Comm.	A	A	A	A	-	-	A	A
Vanilla Extract*	A	-	-	A	-	-	-	-
Water-All Types	A	A	A	A	A	A	A	A
Wetting Agents*	A	-	-	A	-	-	-	-
Whiskey*	A	A	A	A	-	-	A	A
Wines	A	A	A	A	-	-	A	A
Yeast	A	A	-	A	-	-	-	-
Zinc Chloride sat'd	A	A	-	A	-	-	-	-
Zinc Sulfate sat'd	A	A	A	A	A	-	A	A
* Stress Cracking Agent	** No Free Sulfuric Acid							

SERVICE TEMPERATURE LIMITATIONS

Cross-linked polyethylene: -40° F to +150° F

Linear polyethylene: -20° F to +120° F

Note: Constant service temperatures above 100° F greatly reduce useful tank life, please consult factory.

Ratings	Chemical Attack		
A	No Effect	Excellent	At ambient temperature
B	Minor Effect	Good	At ambient temperature
C	Moderate Effect	Fair	Additional research required
D	Severe Effect	NOT RECOMMENDED	
—	No Data		

Put your toughest challenges in our hands.

Not all problems are solvable off-the-shelf. That's why we dig in, ask questions, walk you through your options, and get to know your problems as if they were our own. That's what it takes to arrive at **a solution you won't have to do over.**

View our tanks, accessories, and more at assmann-usa.com



THE
ANSWER
IS YES,
IT CAN
BE DONE.



300 N. Taylor Road, Garrett, IN 46738 • Manufacturing facilities in Garrett, IN and Marshall, TX
Phone 888-357-3181 • Fax 260-357-3738 • info@assmann-usa.com • assmann-usa.com

© 2022 Assmann Corporation of America • All Rights Reserved

AUTHORIZED DISTRIBUTOR:



Missouri Filter & Process Equipment Co
MOFILCO-Quality, Value, Service
12025 Manchester Road, Suite 30G
St Louis MO 63131

314-821-4321 www.mofilco.com
mofilco@mofilco.com