

Packaged Chemical Feed Systems



Missouri Filter & Process Equipment Co
MOFILCO-Quality, Value, Service
12025 Manchester Road, Suite 30G
St Louis MO 63131

314-821-4321 www.mofilco.com
mofilco@mofilco.com

Where Innovation Flows



Neptune[®]

With nearly 60 years of experience in the pumping and chemical industries, Neptune™ is your single-source provider for the reliable and safe handling of critical chemical fluids for water-treatment processes from beginning to end, or “water-in to water-out.” As part of a comprehensive portfolio of components for water-treatment processes, Neptune offers a complete line of packaged chemical feed systems, with or without containment. From polyethylene tank systems and nimble skid flexible pump packages to portable tank feeders and closed containment feed systems, Neptune has your complete chemical feed system, customized to fit your application requirements.



- Polyethylene Tank Systems (single or dual pumps; top- or bottom-mounted)
- Stainless Steel Tank Systems (single or dual pumps; top- or bottom-mounted)
- Containment Feed Systems
- Closed Containment Feed Systems
- Portable Mini Tank Feeders

Polyethylene and Stainless Tank Systems

Bottom-Mounted Chemical Feed Systems

Neptune recommends that the pump be mounted for a flooded suction. Flooded suction is the optimum operating condition for a metering pump.

Standard equipment included with each feed system:

POLYETHYLENE, BOTTOM-MOUNTED

- Polyethylene tank & frame
- Agitator bracket
- Cover (hinged 100-gallon tank and larger)
- PVC suction valve
- Cast iron "Y" strainer
- PVC suction piping
- ½" drain connection

STAINLESS STEEL, BOTTOM-MOUNTED

- Tank, 304SS or 316SS†
- Tank lid (hinged) & stand
- Gauge glass (non-valve type)
- PVC suction valve
- Polyethylene "Y" strainer
- PVC suction piping
- ½" drain connection

Model No.†	Capacity (Gallons)	Tank Material	Shell Thickness	Dimensions (inches)			
				A	B	C	D
50PT	55	Polyethylene	5/32"	61	36	22	16-7/8
100PT	100	Polyethylene	1/4"	75	46	28	16-7/8
50SST-304	50	304SS†	16 gauge	55	29	24	16-7/8
100SST-304	50	304SS†	16 gauge	63	37	30	16-7/8
50SST-316	50	304SS†	16 gauge	55	29	24	16-7/8
100SST-316	50	304SS†	16 gauge	63	37	30	16-7/8

316SS piping, valves and strainer optional.

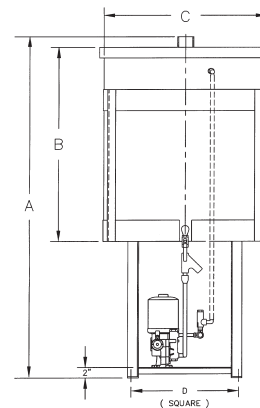

50PT Tank with Metering Pump Bottom Mounted

Top-Mounted Chemical Feed Systems

Mounting the pump on top of the solution tank is a space-saving and economical approach to packaged chemical feed systems.

STANDARD EQUIPMENT INCLUDED WITH EACH FEED SYSTEM:

- Tank
- Hinged cover
- PVC foot valve strainer
- Suction piping
- Steel tank stand
- ½" drain connection

Model No.†	Capacity (Gallons)	Tank Material	Shell Thickness	Dimensions (inches)				
				A	B	C	D	E
TM 50PT	55	Polyethylene	5/32"	41	36	24	15-3/4	56
TM 100PT	100	Polyethylene	1/4"	55	47	30	20	70

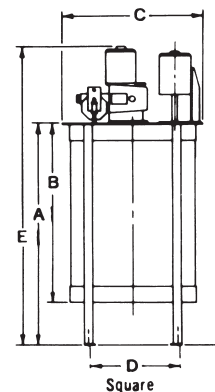

TM 50PT Tank with Metering Pump Top Mounted

Containment Feed Systems

PURPOSE

Neptune containment feed systems are completely packaged chemical feed systems mounted within a containment. The feed tanks are translucent polyethylene, which makes the liquid level readily visible.

The narrow design fits doorways and elevators.

Containment feed systems are ideal for drumless chemical programs.

BENEFITS

- Provides complete, packaged chemical feed system
- Efficiently contains chemical leaks or spills
- Allows total reclamation of any spilled chemical
- Improves housekeeping and maintenance
- Offers easy access to the pumps
- Containment tank volume is 115% of feed tank volume

Portable Mini-Tank Feeders

Mini-tank systems offer portability and economy. Compact design – 24" wide, 36" long, 30" high – fits through doorways and elevators and allows for installation in small areas. Tank removes from the base for ease of transporting and handling. All units include polypropylene suction piping with an isolation valve and "Y" strainer.

- Total weight: 40 lbs. plus pump
- Use with electronic or motor-driven pumps
- 8" manway standard
- Containment available (41" L x 26" W x 13" H)
- Optional agitator
- Optional calibration column



MT-30 Model shown without containment. Pump, agitator, and calibration column shown are sold separately.

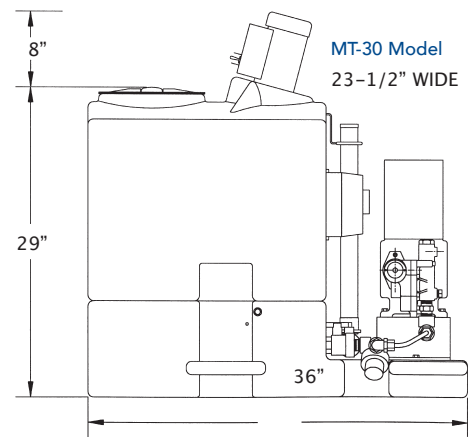

MT-30 Model shown with optional containment tank MT-CT. Tank size and shape shown in image are for reference only. Please see containment tank measurement in table.

Pump, agitator, and calibration column shown are sold separately.

Model	Capacity (Gallons)
MT-30	30 Gallon System includes polypropylene suction piping with isolation valve and "Y" strainer. (Pump, agitator, and calibration column are sold separately)
MT-30T	30 Gallon Molded Tank and Base Only. Piping kit and strainer not included.
Optional Accessories (Sold Separately)	
MT-CC	Calibration Column Piping Option for MT-30
MT-CT	90 Gallon (24" x 48" x 18") Black External Leak and Spill Containment Tank Option for MT-30
MTA	On Tank Agitator Option for MT-30

May be used with PZ Series Electronic Diaphragm Pumps or 500E/500A Series Hydraulic Diaphragm Metering Pumps.

Type EC

Economy EC units are available with one or two feed tanks in a single containment tank. They may be specified with single or dual feed tanks.

No accessories are included. The molded cover provides a mounting area for the pump and mixer, plus 1" and 4" fill ports with caps.

Model	Cover Style	Capacity (Gallons)	
		Day Tank	Contain. Tank
EC-50-1	Molded	55	90

Model EC-50-1 with molded cover and optional pumps

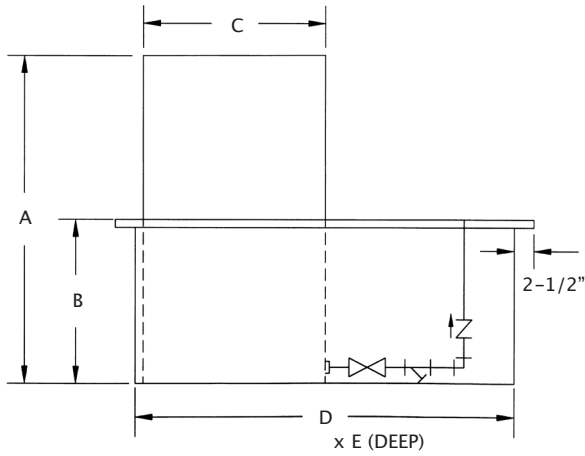

Model	Dimensions (inches)				
	A	B	C (DIA.)	D	E
EC-50-1	37	20-1/2	23	48	24

Closed Containment Feed Systems

The standard unit includes a containment basin and a 60-gallon tank with a gasketed cover for the containment area held in place with latches. Each unit includes polypropylene suction piping with a ½" polypropylene valve and strainer. A flexible polyethylene hose with a ½" threaded connector is provided from the strainer to the pump.

Containment feed systems are ideal for drumless chemical programs.

- Boiler or cooling tower controls and pushwater piping can be installed entirely with containment
- Gasketed cover with latches allows reclaim of uncontaminated chemicals in the event of leakage or spillage
- OUTDOOR: Prevents rainwater and debris from collecting in the containment
- INDOOR: Prevents containment from becoming a convenient refuse receptacle

Model	Capacity (Gallons)	
	Day Tank	Contain. Tank
CFS-60	60	110

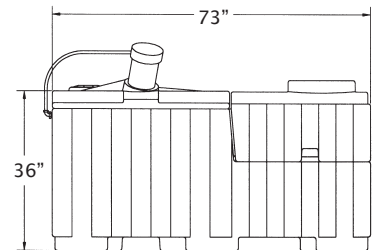

Model CFS-60

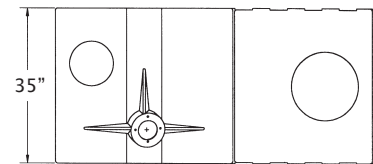

Top View –
CFS-60



Closed Containment Feed System

Options and Accessories	
Model	Description
EDA-50C	Double wall discharge line 20' long
CC-1	100 ml. calibration cylinder with isolation valve
CC-2	250 ml. calibration cylinder with isolation valve
CSA-1.0	Mixer, direct drive, 4" prop 316SS propeller and shaft Motor with cord and plug 1/4hp-1ph-60hz-115/230v-TEFC

Portable Mini-Tank Feeders

Economy Feed Systems

ST TANKS: USE WITH PZ SERIES PUMPS

- ST-50: 55-gallon tank
- Package included:
 - High-density polyethylene tank with cover
 - Cover cutout for mixer and pump suction line
 - 1" and 4" fill ports with caps

ET-P TANKS: USE WITH 500 SERIES, 500A SERIES OR 500E SERIES METERING PUMPS

- 55-gallon tank only
- Model ST-50 (above), plus:
 - Rigid PVC suction assembly
 - PVC foot valve strainer
 - Pump mounting plate
 - Stainless steel lid reinforcing bars

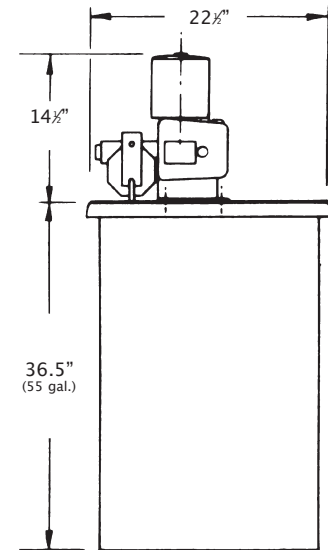

500E Series Metering Pump
with Model ET-P TANK

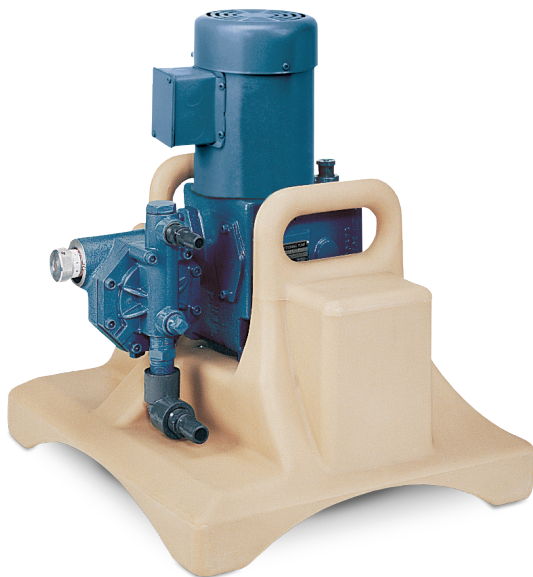

EZE-Grab Pump Platforms

Single-piece, molded polyethylene base with handles allows the pump to be lifted and moved easily. It also provides an elevated platform for use indoors or outdoors when another mounting system is not available.

- Use with bulk or semi-bulk tanks or drums
- Convenient for trials or temporary installations
- Four-point contact allows clearance for washdown under the base

Part No.	Description
106874	Platform Only*

*Fits all 500S and 500D Series models.
*Specify adaptor kit part #003582 to adapt 500A, 500E or 560 Series duplex



PSG
22069 Van Buren Street
Grand Terrace
CA, 92313-5651
USA
P: +1 (909) 422-1700
F: +1 (909) 783-3440
psgdover.com/neptune



Where Innovation Flows

NPT-10009-C-02

Authorized PSG® Partner:

Copyright 2023 PSG®, a Dover company



Missouri Filter & Process Equipment Co
MOFILCO-Quality, Value, Service
12025 Manchester Road, Suite 30G
St Louis MO 63131

314-821-4321 www.mofilco.com
mofilco@mofilco.com