

Glycol Feed Systems



Where Innovation Flows



Neptune™ Glycol Feeders are designed for the addition of glycol solution to closed-loop chilled or hot water systems to maintain pressure in the loop by making up for losses that occur due to leakage.

Glycol addition is controlled by a pressure switch with adjustable low and high set points*. When the pressure in the loop reaches the low set point, the pump begins to feed glycol into the system until the high-pressure set point is achieved and the switch stops the pump.

*The standard pressure switch features the following ranges:
Cut-in (low) range: 10-45 psi (0.7-3.1 bar); Cut-out (high) range: 20-60 psi (1.4-4.1 bar);
Adjustable differential: 10-30 psi (0.7-2.1 bar). Other pressure switches are available.

FEATURES AND BENEFITS

- 55 gallon (208 liters) polyethylene tank mounted in a steel frame
- Bronze rotary gear pump
- Float switch for low level pump shutoff and alarm
- NEMA 4X control panel includes:
 - Hand off auto selector switch for pump motor
 - Pump (on) indicator light
 - (Low) tank level indicator light
 - Dry contact for remote low-level indication
 - Power cord with plug, 115V AC (60Hz) or 230V AC (50Hz)
- Max pressure up to 100 psi (6.9 bar)
- Max capacity up to 1.5 gpm (5.7 L/h)

OPTIONS

- Optional audible alarm (not watertight) and push-button silence available

MODEL G-50-1 & G-50-1A

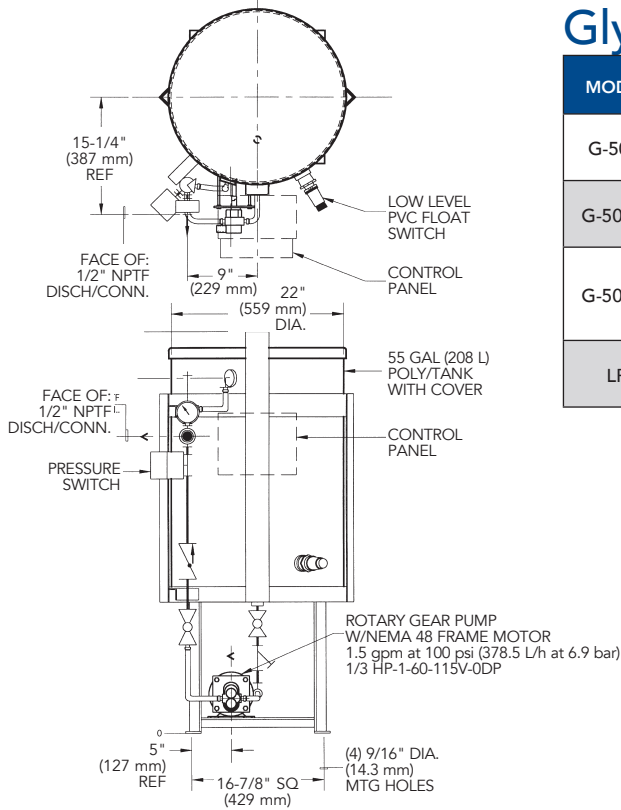

MODEL G-50-2A

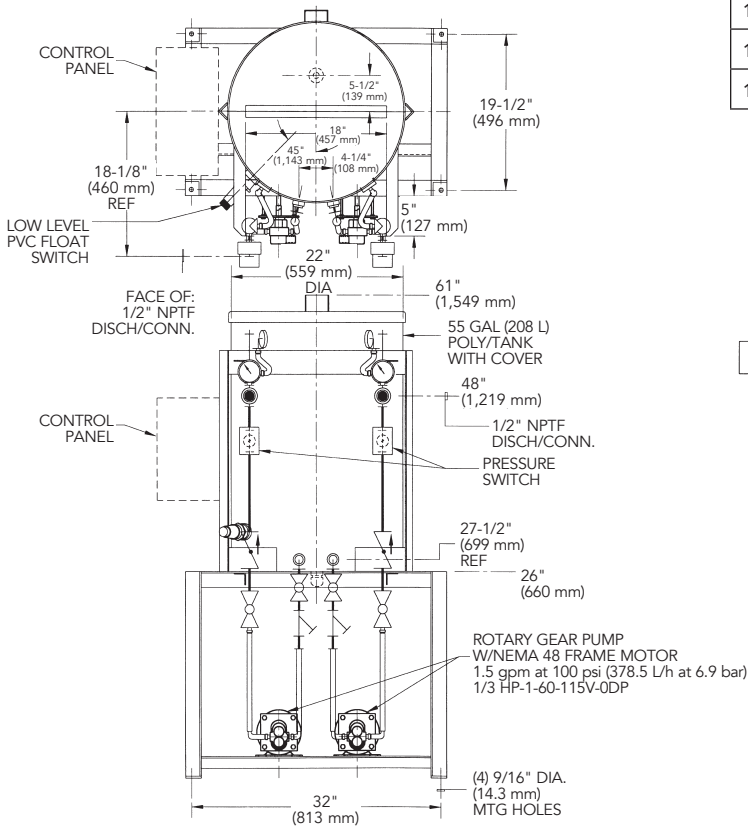

Glycol Feed Systems

SELECTION CHART

MODEL	DESCRIPTION
G-50-1	Complete system including 1.5 gpm at 100 psi (5.7 L/min at 6.9 bar) pump and low-level light.
G-50-1A	Complete system including 1.5 gpm at 100 psi (5.7 L/min at 6.9 bar) pump, low level light and audible alarm.
G-50-2A	Complete system including two 1.5 gpm at 100 psi (5.7 L/min at 6.9 bar) pumps, low level light and audible alarm. Separate discharge and pressure switches allow feeding two separate closed-loop systems independently from a single tank.
LP	Option to furnish larger pump rated 3.75 gpm at 100 psi (14.2 L/min at 6.9 bar). Add "LP" to Model Number to specify larger pump; Example G-50-1-LP.

MATERIALS OF CONSTRUCTION

EACH DISCHARGE ASSEMBLY CONTAINS:
1/2" S40/ Brass/ Pipe w/ NPT Fittings
1/2" Ball Valve/ PVC
1/2" Check Valve/ Brass
1/2" Relief Valve/ Brass set at 100 psi (6.9 bar) w/PVC Return Line
Pressure Gauge 0-100 psi (0-6.9 bar)
Pressure Switch
EACH SUCTION ASSEMBLY CONTAINS:
1/2" S80/ PVC Pipe w/ NPT Fittings & PVC Tubing
1/2" PVC Ball Valve
1/2" Cast Iron Y-Strainer

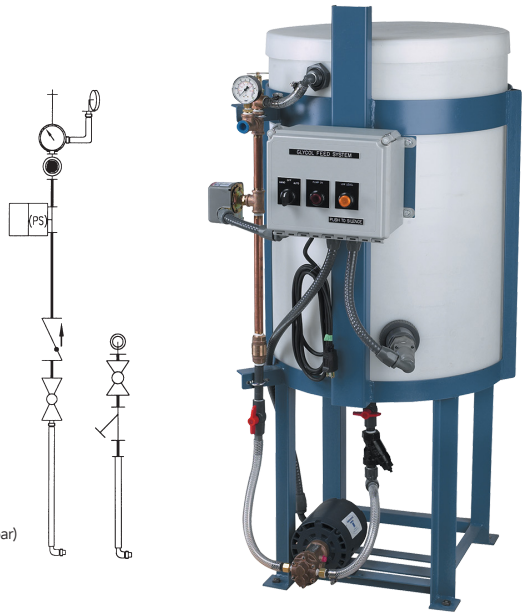

Model G-50-1

Where Innovation Flows



Neptune
 PSG
 22069 Van Buren Street
 Grand Terrace, CA 92313-5651 USA
 P: +1 (909) 422-1700 • F: +1 (909) 783-3440
psgdoover.com/neptune

Distributed By:

Missouri Filter & Process Equipment Co
 MOFILCO-Quality, Value, Service
 12025 Manchester Road, Suite 30G
 St Louis MO 63131
 314-821-4321 www.mofilco.com
 mofilco@mofilco.com