

Fiberglass Shot Feeder



Where Innovation Flows



Missouri Filter & Process Equipment Co.
MOFICO-Quality, Value, Service
12025 Manchester Road, Suite 300
St. Louis MO 63131
314-821-4321 www.mofico.com
mofico@mofico.com

Neptune Fiberglass By-Pass Feeders are a convenient and efficient way to properly feed liquid, granular or solid chemicals for water treatment. Vinylester resin body tanks are superior to standard steel by-pass feeders for shot feeding corrosive chemicals.

FEATURES AND BENEFITS

- Three sizes available: 15, 40 and 80 lb. (6.8, 18.1 and 36.3 kg) capacities
- Threaded, gasketed closure
- Two threaded side connections
- Rated up to 150 psi at 150°F (10.3 bar at 66°C)

OPTIONS

- PVC piping kits include distributor/strainers and all required fittings. Fittings rated up to 120 psi at 100°F (8.3 bar at 38°C)
- Flow indicators
- Pressure relief valves and solenoid valves

Specifications

TANKS

Vinylester resin bodies have two threaded side connections and one 2-3/4" (69.9 mm) or 4" (101.6 mm) top opening with threaded gasketed closure. Tanks rated to 150 psi at 150°F (10.3 bar at 66°C).

MODEL	CAPACITY			DIMENSIONS INCHES (MM)				CLOSURE IN. (MM)	CONN. SIZE NPT	SHIP WT. LB. (KG)
	GAL. (L)	FT. ³ (M ³)	LB. (KG)*	A	B	C	D			
BR-2	2.3 (8.7)	0.3 (.009)	15 (6.8)	18-1/2 (469.9)	6 (152.4)	9-3/8 (238.1)	4-5/8 (117.5)	2-1/2 (64)	3/4	5 (2)
BR-5	5.0 (18.9)	0.7 (.02)	40 (18.1)	30-1/2 (774.7)	7 (177.8)	21 (533.4)	4-1/4 (108.0)	2-1/2 (64)	3/4	8 (4)
BR-10	10.0(37.9)	1.4 (.04)	80 (36.3)	35-3/8 (898.5)	10 (254.0)	23-3/4 (603.3)	5-1/2 (139.7)	4 (102)	3/4	17 (8)

*Capacity in lb. of tablets; capacity reduced by 50% for granular product.

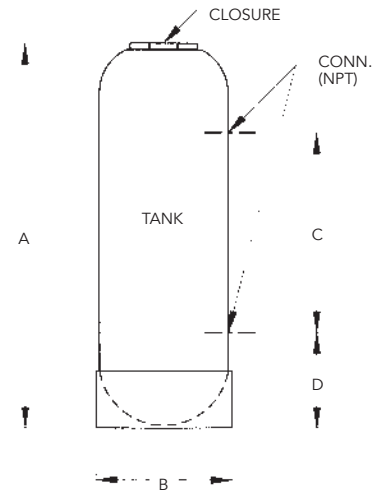

PIPING KITS

PVC threaded fittings for operation to 120 psi at 100°F (8.3 bar at 38°C).

Kit contains: two strainers, three ball valves, two tees, two 90° elbows, required nipples and plugs.

MODEL	DESCRIPTION	USE WITH	SHIP WT. LB. (KG)
BP-75	3/4" NPT Piping Kit includes two 3/4" x 1/2" (19 mm x 13 mm) bushings to adapt flow indicators.	BR-2, BR-5, BR-10	5 (2)

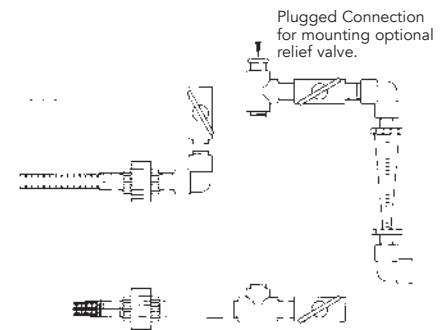

FLOW INDICATORS

5% accuracy, Polysulfone and CPVC with 316SS float. Male pipe connections rated to 150 psi at 120°F (10.3 bar at 49°C).

MODEL	RANGE GPM (L/MIN)	CONN. SIZE NPT	USE WITH	SHIP WT. LB. (KG)
FI-1	0.1 - 1 (0.4 - 3.8)	1/2	BR-2, BR-5, BR-10	1 (0.5)
FI-2	0.2 - 2 (0.8 - 7.6)	1/2	BR-2, BR-5, BR-10	1 (0.5)
FI-5	0.5 - 5 (1.9 - 18.9)	1/2	BR-5, BR-10	1 (0.5)
FI-10	1 - 10 (3.8 - 37.9)	3/4	BR-10	2 (0.9)

Dual Size Closure Wrench

Glass filled polypropylene wrench fits both 2-1/2" (63.6 mm) and 4" (101.6 mm) closures.

Part Number 107282



RELIEF VALVE

Specify RV-BR for 1/2" (12.7 mm) PVC safety relief valve. (Required for bromine service.) Set at 50 psi (3.5 bar). Includes elbow, adapter, hose clamp and 4' (1.2 m) of tubing to pipe relief outlet away.

FUNNELS

Polyethylene funnels are available in two sizes to fit the 2-1/2" or 3-3/4" top opening of the bromine feeder body.

PART NUMBERS	FITS MODELS	DIMENSIONS INCHES (MM)		
		A	B	C
106894	BR-2, BR-5	2-3/8 (60.3)	7-1/2 (190.5)	9-1/2 (241.3)
106809	BR-10	3-1/2 (88.9)	7 (177.8)	11-1/2 (292.1)

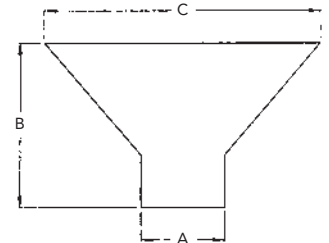

BR-19
NPT-10220-F-01

Where Innovation Flows



Authorized PSG® Partner:

Copyright 2020 PSG®, a Dover company



PSG
22069 Van Buren Street
Grand Terrace, CA 92313-5651 USA
P: +1 (909) 422-1700 • F: +1 (909) 783-3440
psgdoover.com/neptune



Missouri Filter & Process Equipment Co
MOFILCO-Quality, Value, Service
12025 Manchester Road, Suite 30G
St Louis MO 63131

314-821-4321 www.mofilco.com
mofilco@mofilco.com